

Dell™ Laser Printer 5100cn

# Owner's Manual

**Look Inside For:**

- **Loading Paper**
- **Setting Up for Local and Network Printing**
- **Installing Printer Driver**
- **Using Your Printer**
- **Maintenance**
- **Contacting Dell**

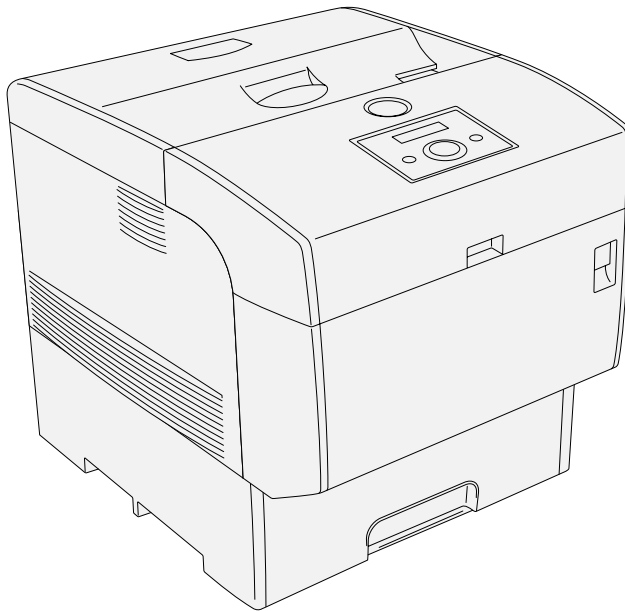

# Order Printer Supplies

Dell™ Printer Supplies are available only through Dell. You can order Printer Supplies online at [www.dell.com/supplies](http://www.dell.com/supplies) or by phone.

---

<b>US</b>	877-INK-2-YOU	<b>Malaysia</b>	1800 88 0301
<b>Algeria</b>	Contact your distributor.	<b>Mexico</b>	866-851-1754
<b>Argentina</b>	Contact your distributor.	<b>Netherlands</b>	020-674-4881
<b>Australia</b>	1300 030 290	<b>Norway</b>	231622 64
<b>Austria</b>	08 20-24 05 30 35	<b>Oman</b>	Contact your distributor.
<b>Belgium</b>	02.713 1590	<b>Paraguay</b>	Contact your distributor.
<b>Canada</b>	1-877-501-4803	<b>Peru</b>	Contact your distributor.
<b>Caribbean Islands</b>	Contact your distributor.	<b>Poland</b>	022 579 59 65
<b>Chile</b>	800-202874 1230-020-3947	<b>PRC</b>	800-858-0888
<b>Colombia</b>	01800-9-155676	<b>Puerto Rico</b>	866-851-1760
<b>Czech Republic</b>	420 225 372 711	<b>Qatar</b>	Contact your distributor.
<b>Denmark</b>	3287 5215	<b>Russia</b>	Contact your distributor.
<b>Egypt</b>	Contact your distributor.	<b>Saudi Arabia</b>	Contact your distributor.
<b>Finland</b>	09 2533 1411	<b>Singapore</b>	1800 394 7486
<b>France</b>	825387247	<b>South Africa</b>	0860 102 591
<b>Germany</b>	0800 2873355	<b>Spain</b>	902 120 385
<b>Ireland</b>	1850 707 407	<b>Sweden</b>	08 587 705 81
<b>Israel</b>	Contact your distributor.	<b>Switzerland</b>	0848 335 599
<b>Italy</b>	800602705	<b>Tunisia</b>	Contact your distributor.
<b>Japan</b>	044-556-3551	<b>Turkey</b>	Contact your distributor.
<b>Jordan</b>	Contact your distributor.	<b>UAE</b>	Contact your distributor.
<b>Kuwait</b>	Contact your distributor.	<b>UK</b>	0870 907 4574
<b>Lebanon</b>	Contact your distributor.	<b>Uruguay</b>	Contact your distributor.
<b>Luxembourg</b>	02.713 1590	<b>Venezuela</b>	Contact your distributor.
		<b>Yemen</b>	Contact your distributor.

---

# Dell™ Laser Printer 5100cn

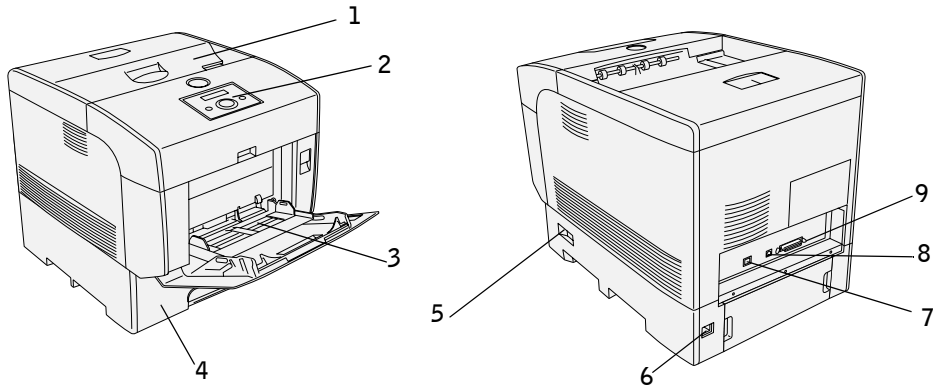

<b>1</b> Center output tray	<b>5</b> Power switch
<b>2</b> Operator panel	<b>6</b> Power cable connector
<b>3</b> Multipurpose feeder	<b>7</b> Ethernet port
<b>4</b> Standard 500-sheet tray	<b>8</b> USB port
	<b>9</b> Parallel port

For details on the optional 500-sheet tray module, 1000-sheet tray module, and other additional options, see the *User's Guide*.

## Notes, Notices, and Cautions



**NOTE:** A **NOTE** indicates important information that helps you make better use of your printer



**NOTICE:** A **NOTICE** indicates either potential damage to hardware or loss of data and tells you how to avoid the problem.



**CAUTION:** A **CAUTION** indicates a potential for property damage, personal injury, or death.

---

Information in this document is subject to change without notice.

© 2004 Dell Inc. All rights reserved.

Reproduction in any manner whatsoever without the written permission of Dell Inc. is strictly forbidden.

Trademarks used in this text: *Dell* and *DELL* logo are trademarks of Dell Inc.; *Microsoft* and *Windows* are registered trademarks of Microsoft Corporation; *Novell* and *NetWare* are registered trademarks of Novell, Inc.; *UNIX* is a registered trademark of The Open Group in the United States and other countries; *PCL* is US registered trademark of Hewlett-Packard Company.

Other trademarks and trade names may be used in this document to refer to either the entities claiming the marks and names of their products. Dell Inc. disclaims any proprietary interest in trademarks and trade names other than its own.

### UNITED STATES GOVERNMENT RESTRICTED RIGHTS

This software and documentation are provided with RESTRICTED RIGHTS. Use, duplication or disclosure by the Government is subject to restrictions as set forth in subparagraph (c)(1)(ii) of the Rights in Technical Data and Computer Software clause at DFARS 252.227-7013 and in applicable FAR provisions: Dell Inc., One Dell Way, Round Rock, Texas, 78682, USA.

### FCC emissions information

This equipment has been tested and found to comply with the limits for a Class B digital device, pursuant to Part 15 of the FCC rules. Refer to the *Drivers and Utilities* CD for details.

# Contents

Dell™ Laser Printer 5100cn .....	3
<b>1 Loading Paper .....</b>	<b>11</b>
Loading the Standard Tray .....	12
Loading the Multipurpose Feeder .....	15
Loading Envelopes .....	17
<b>2 Setting Up for Local Printing .....</b>	<b>19</b>
Installing Printer Drivers .....	20
Connecting the Printer to the Computer Before Inserting the Drivers and Utilities CD .....	20
<b>3 Setting Up for Network Printing .....</b>	<b>23</b>
Network Set-Up .....	24
Disable Microsoft® Windows® XP Firewall Before Printer Software Installation .....	24
Print and Check the Printer Settings Page .....	24
Run the Installation Software .....	25
<b>4 Installing the Printer Driver or PPD File on Macintosh Computers .....</b>	<b>27</b>
Installing the AdobePS Printer Driver (Mac OS 9.x) .....	28
Setting the Printer Driver (for AppleTalk Connection) .....	28
Setting the Printer Driver (for USB Connection) .....	29
Configuring Settings .....	30
Adding a Printer .....	31
Configure Settings .....	32

<b>5 Using Your Printer .....</b>	<b>33</b>
<b>Changing Printer Settings .....</b>	<b>34</b>
Initializing NVRAM .....	35
Setting of Panel Lock .....	35
<b>Adjusting the Language .....</b>	<b>36</b>
<b>Printing a Job .....</b>	<b>36</b>
<b>Canceling a Job From the Printer Operator Panel .....</b>	<b>36</b>
<b>Canceling the Job From a Computer .....</b>	<b>36</b>
Canceling a Job From the Taskbar .....	36
Canceling a Job From the Desktop .....	37
<b>Software Overview .....</b>	<b>37</b>
Printing Status Window .....	37
Status Window .....	37
Status Monitor Console .....	37
Dell Supplies Management System .....	38
User Setup Disk Creating Tool .....	38
Software Update .....	38
<b>6 Maintenance .....</b>	<b>39</b>
<b>Replacing the Imaging Drum .....</b>	<b>40</b>
Removing the Used Imaging Drum .....	40
Installing the New Imaging Drum .....	41
<b>Replacing the Toner Cartridge .....</b>	<b>43</b>
Removing the Used Toner Cartridge .....	43
Installing the New Toner Cartridge .....	44
<b>Replacing the Transfer Roller .....</b>	<b>47</b>
Removing the Used Transfer Roller .....	47
Installing the New Transfer Roller .....	48
<b>Replacing the Fuser and Separator Roller .....</b>	<b>50</b>
Removing the Used Fuser .....	50
Installing the New Fuser .....	52
Removing the Used Separator Roller .....	53
Installing the New Separator Roller .....	54

Cleaning the Automatic Density Control (ADC) Sensor .....	56
<b>7 Appendix .....</b>	<b>61</b>
<b>Technical Assistance .....</b>	<b>62</b>
<b>Automated Order-Status Service .....</b>	<b>62</b>
<b>Contacting Dell .....</b>	<b>63</b>
<b>U.S. Terms and Conditions of Sale .....</b>	<b>79</b>
<b>Limited Warranties and Return Policy .....</b>	<b>81</b>
Limited Warranty for Dell-Branded Hardware Products (U.S. Only) .....	81
Total Satisfaction Return Policy (U.S. Only) .....	85
Limited Warranty Terms for Dell-Branded Hardware Products (Canada Only) .....	85
Total Satisfaction Return Policy (Canada Only) .....	88
Dell Software and Peripherals (Canada Only) .....	89
1-Year End-User Manufacturer Guarantee (Latin America and the Caribbean Only) .....	89
<b>Dell Inc.</b>	
<b>Ink and Toner Cartridges Limited Warranties .....</b>	<b>91</b>
Ink and Toner Cartridges Limited Warranty (U.S. and Canada Only) .....	91
Ink and Toner Cartridges Limited Warranty (Latin America Only) .....	91
<b>Dell™ Software License Agreement .....</b>	<b>93</b>
Limited Warranty .....	93
U.S. Government Restricted Rights .....	94
General .....	94
<b>Regulatory .....</b>	<b>94</b>
<b>Index .....</b>	<b>97</b>





## **CAUTION: SAFETY INSTRUCTIONS**

Use the following safety guidelines to help ensure your own personal safety and to help protect your system and working environment from potential damage.

- Your product uses a laser.

 **CAUTION: Use of controls or adjustments or performance of procedures other than those specified herein may result in hazardous radiation exposure.**

- Your product uses a printing process that heats the print media, and heat can cause certain media to release emissions. You must understand the section in your operating instructions that discusses the guidelines for selecting appropriate print media to avoid the possibility of harmful emissions.

 **CAUTION: If your product is not marked with this symbol , it must be connected to an electrical outlet that is properly grounded.**

- The power cable must be connected to an electrical outlet that is near the product and easily accessible.
- Refer service or repairs, other than those described in the operating instructions, to a professional service person.
- This product is designed to meet safety standards with the use of specific Dell-authorized components. The safety features of some parts may not always be obvious. Dell disclaims liability associated with use of non-Dell-authorized components.

 **CAUTION: To move the printer safely, remove the optional 500- and 1000-sheet tray module before moving the printer.**



Section 1

## **Loading Paper**

---

Loading the Standard Tray

Loading the Multipurpose Feeder

Loading Envelopes

## Loading the Standard Tray

Load the print media used for the majority of your print jobs in the standard 500-sheet tray.

1. Pull the tray out of the printer until it stops. Hold the tray with both hands, lift the front slightly, and remove it from the printer.

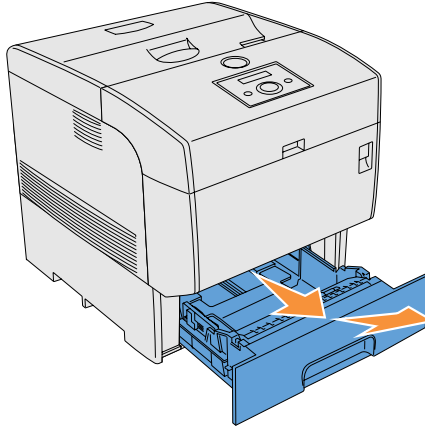

2. Slide the width guides to the edge of the tray. The width guides should be fully extended.

 **NOTE:** For A4 paper, push the lever to the A4 position.

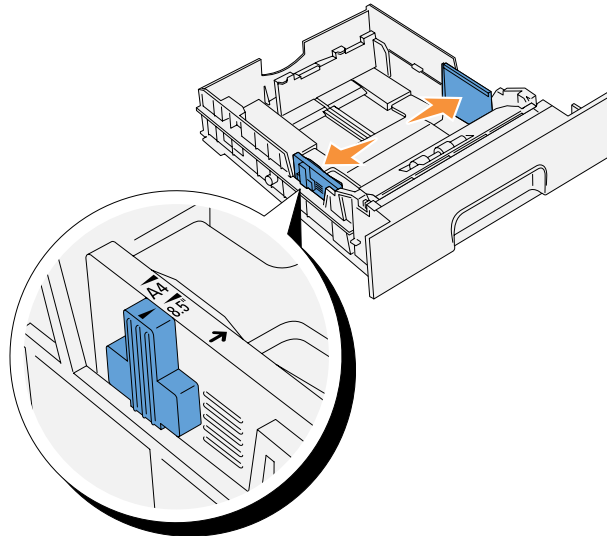

3. Squeeze the length guide and slide it to the edge of the tray.

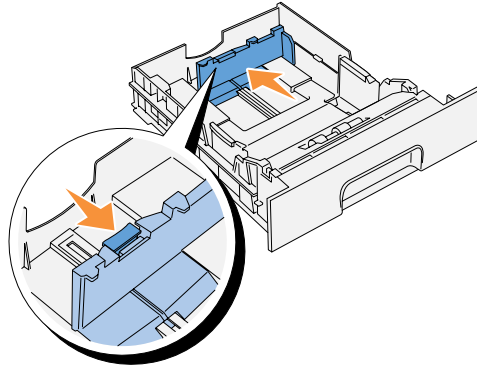

4. Before loading the print media, flex the sheets back and forth, and then fan them. Straighten the edges of the stack on a level surface.

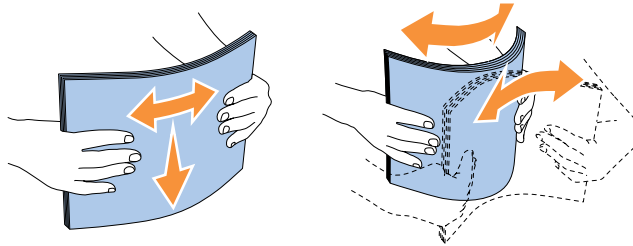

5. Place the print media into the tray with the recommended print side face up.

 **NOTE:** Do not exceed the maximum fill line in the tray. Overfilling the tray may cause paper jams.

6. Slide the width guides and length guide until they rest lightly against the edge of the print media stack.

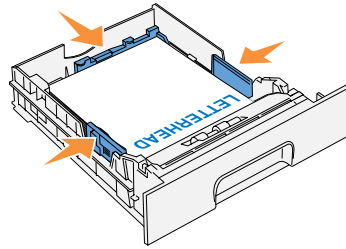

7. Insert the tray into the printer, and push until it stops.
8. If you load any print media into the tray, configure the Paper Type settings for that tray according to the message on the operator panel.

## Loading the Multipurpose Feeder

In addition to plain paper, the multipurpose feeder can use various other sizes and types of print media such as envelopes and transparencies.

1. Gently pull open the multipurpose feeder cover, and pull out the extension tray.

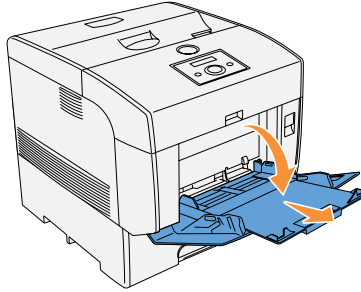

2. Slide the width guides to the edge of the tray. The width guides should be fully extended.

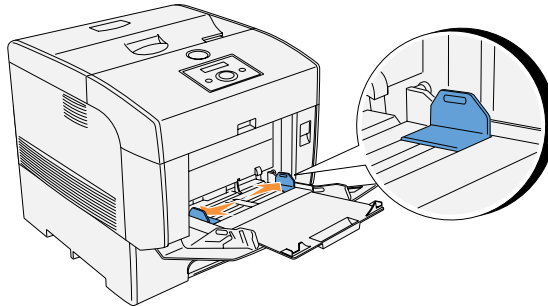

3. Insert all media face down and top edge first into the multipurpose feeder. For more information, see "Loading Envelopes" on page 17.

 **NOTE:** Do not force the print media.

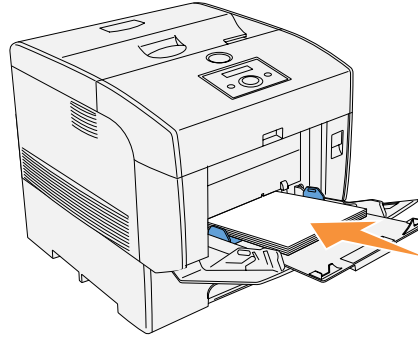

4. Slide the width guides until they rest lightly against the edge of the print media stack.

 **NOTE:** Be careful not to bend the print media.

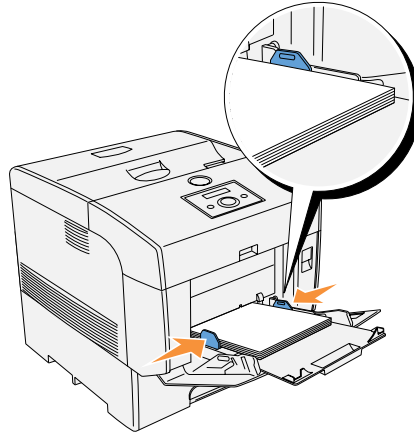

5. Make sure the size and type settings for the multipurpose feeder are set to the correct value for the print media you have loaded.

Select print media source, size, and type in your software program and select the print media size and type on the printer operator panel.

For tips on recommended print media, solving printing problems, and clearing jams, see the *User's Guide*.



## Loading Envelopes

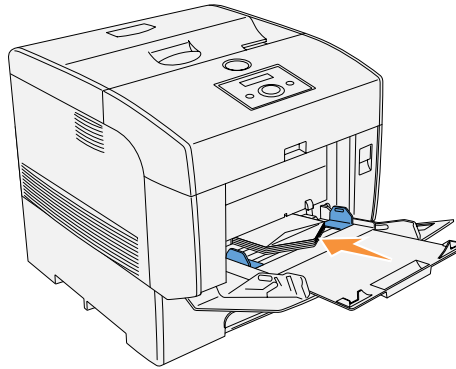

To load envelopes that are under 8.66 inches (220 mm) in width in the multipurpose feeder, insert the envelopes either with the flaps closed and at the right side or the flaps open and at the rear. To load envelopes that are over 8.66 inches (220 mm) in width in the multipurpose feeder, insert the envelopes with the flaps closed and the short-edge of the envelopes facing into the printer. The print side must be facing down. You can load envelopes up to the maximum fill line in the tray at one time.



**NOTICE:** Never use envelopes with windows, coated linings, or self-stick adhesives. These lead to paper jams and damage to the printer.

After loading envelopes, make sure the size and type setting for the multipurpose feeder is set to the correct value for the print media you have loaded. Select print media source, size, and type in your software program and select the print media size and type on the printer operator panel.



Section 2

## Setting Up for Local Printing

---

Installing Printer Drivers

A local printer is a printer attached to your computer or a print server using a USB or parallel cable. If your printer is attached to a network and not your computer, see "Setting Up for Network Printing" on page 23.

## Installing Printer Drivers

### Connecting the Printer to the Computer Before Inserting the Drivers and Utilities CD

 **NOTE:** Using this setup method, make sure your printer is not connected to your computer when you begin.

After the printer driver has been installed, you need to do the Installable Options settings in Printer Property are needed according to the options you installed.

#### Windows 98, Me, 2000, XP and Server 2003

1. Connect your printer to your computer.
2. When the **Found New Hardware Wizard** appears, click **Cancel**.
3. Insert the *Drivers and Utilities* CD into your computer.
4. Click **Personal Installation**.
5. Click **Install**. The **Found New Hardware Wizard** appears.
6. Click **Next**. The wizard automatically finds and installs the corresponding printer driver.
7. When the **Complete the Found New Hardware Wizard** screen appears, click **Finish**.
8. Select either the **Typical Installation** or **Custom Installation** checkbox, and then click **Next**. If you select **Custom Installation**, you can select the specific software you want to install.
9. When using Windows 98 or Me, the Adobe License Agreement appears, click to accept the agreement and then click **Install**.
10. When the **Congratulations!** screen appears, in Windows 2000, Windows XP, and Server 2003, click **Printer Test Page** if necessary. Click **Finish**.
11. Click **Cancel**.

#### Windows 95 and NT 4.0

1. Connect your printer to your computer.
2. Insert the *Drivers and Utilities* CD into your computer.

3. Click **Personal Installation**.
4. On the **Add Printer** screen, select the port name from the **Port Name** combo box, and then set the printer's options under **Printer Configuration**. Click **Next**.
5. Select either the **Typical Installation** or **Custom Installation** checkbox, and then click **Next**. If you select **Custom Installation**, you can select the specific software you want to install.
6. The Adobe License Agreement appears, click to accept the agreement and then click **Install**.
7. When the **Congratulations!** screen appears, click **Finish**.
8. Click **Cancel**.





Section 3

## **Setting Up for Network Printing**

---

Network Set-Up

## Network Set-Up

-  **NOTE:** To use this printer in a UNIX or Linux environment, you need to install a UX Filter or Linux Driver. For more information on how to install and use these, refer to your *User's Guide*.
-  **NOTE:** When using a CD drive in a Linux environment, you need to mount the CD according to your system environment. The command strings are `mount/media/cdrom`.
-  **NOTE:** For additional network set-up configurations, refer to your *User's Guide*.

### Disable Microsoft® Windows® XP Firewall Before Printer Software Installation

-  **NOTE:** This step may not be necessary if you have Windows XP Service Pack 2 installed.

If your printer is connected directly to a network and the Windows XP firewall is enabled, you cannot view your networked printer(s) when you run the Dell™ printer installation software. To prevent this situation, disable the Windows XP firewall before you install the Dell printer software. To disable or enable your XP firewall, perform the following steps.

-  **NOTICE:** Dell recommends that you enable your Windows XP firewall after you install the printer software. Enabling the Windows XP firewall after you install the printer software does not limit the use of your network printer.

1. Click the **Start** button and click **Help and Support**.
2. In the **Search** box, type `firewall` and then click the green arrow.
3. In the **Pick a Task** list, click **Enable or disable Internet Connection Firewall** and then follow the instructions on the screen.

### Print and Check the Printer Settings Page

1. Print the Printer Settings page.
  - a. When **Ready to Print** appears in the LCD, press **Menu**.
  - b. Press **▼** until **Configure** appears, and then press **▶** or **↵**.
  - c. Press **▼** until **Reports** appears, and then press **▶** or **↵**.
  - d. **Printer Settings** is displayed. Press **↵**.  
The Printer Settings page is printed.
2. Under the **TCP/IP** heading, verify the IP address.  
If the IP address is `0.0.0.0`, wait for a few minutes to resolve the IP address automatically, and then print the Printer Settings page again.



## Run the Installation Software

1. Insert the *Drivers and Utilities* CD into your computer.
2. The *Drivers and Utilities* CD should launch the installation software automatically.  
If the CD does not automatically launch, click **Start** → **Run**, type `D:\CDFE.exe` (where D is the drive letter of your CD), and then click **OK**.
3. When the *Drivers and Utilities* CD screen appears, click **Network Installation - Install the printer for use on a network**. If using Windows XP, Windows 2000, Windows NT 4.0, or Windows 2003 Server, go to step 4. For all other operating systems, go to step 5.
4. For local installation, select **Local Installation - Install printer on this computer**, and then click **Next**.

For remote installation:

- a. Select **Remote Installation - Install printer on one or more remote computers**, and then click **Next**.
  - b. Enter your Administrator user name, password, and clients or servers and then click **Add**.
  - c. Click **Next**.
5. Select the network printer you would like to install. If you do not see your printer listed, click **Update** to refresh the list or click **Add Printer** to add a printer to the network. You may update the IP address and port name at this point. Click **Next**.



**NOTE:** When using AutoIP, 0.0.0.0 is displayed in the installer. Before you can continue, you must enter a valid IP address.

6. Select your printer from the list. If you would like to change the printer name listed, enter a new name in the Printer Name field.
7. If you want other users on the network to access this printer, select **Share this printer with other computers on the network**, and then enter a share name that users will easily identify.
8. If you want to set a printer as the default, select the printer and then click the **Set this printer as default** check box.
9. If you want to restrict color printing, select the appropriate **Color Track** option. Enter the password.
10. If the **PS Driver** is available and you want to install it, click on the check box.
11. Click **Next**.

12. Select the software and documentation you want to install. You can specify the destination folder to install the Dell software and documentation. To change the destination folder, click **Browse...**
13. Click **Next**.
14. For PostScript Driver Installation Only- If the Adobe License Agreement appears, click to accept the agreement and then click **Install**.
15. When the **Congratulations!** screen appears, select whether or not to restart your computer, and then click **Finish**.

Use the **Dell Printer Configuration Web Tool** to monitor the status of your network printer without leaving your desk. You can view and/or change the printer configuration settings, monitor toner level, and when it is time to order replacement consumables, just click the Dell supplies link right from your Web browser.

 **NOTE:** The **Dell Printer Configuration Web Tool** is not available when the printer is locally attached to a computer or a print server.

To launch the **Dell Printer Configuration Web Tool**, type the network printer IP address in your Web browser, and the printer configuration appears on the screen. Refer to your *User's Guide* for more information.

You can set up the **Dell Printer Configuration Web Tool** to send you an email when the printer needs supplies or intervention.

To set up e-mail alerts:

1. Launch the **Dell Printer Configuration Web Tool**.
2. Click **E-Mail Alert** link.
3. Under **Setup E-Mail Lists and Alerts**, enter the **Primary SMTP Gateway**, the **Reply Address**, and enter your email address or the key operator's email address in the email list box.
4. Click **Apply New Settings**.

 **NOTE:** The SMTP server will display **Connection in Progress** until an error occurs.

Section4

# Installing the Printer Driver or PPD File on Macintosh Computers

---

Installing the AdobePS Printer Driver (Mac OS 9.x)

Installing the PPD File (Mac OS X)

## Installing the AdobePS Printer Driver (Mac OS 9.x)

There are two steps to install the printer driver. First, you must use the installer included in the *Drivers and Utilities* CD to install the printer driver to Macintosh. Then configure the printer driver according to the connection type.

1. Insert the *Drivers and Utilities* CD into your computer.
2. Launch the *Drivers and Utilities* CD.
3. Open the Mac OS 9 folder.
4. Double click the desired language folder (for example, **English**) you want to install.
5. Double click **Dell 5100cn Installer** icon.
6. Select the way you want to install the program.
  - Select **Full Installation** to install the AdobePS printer driver and PPD file.
  - Select the **Custom Installation** to install the PPD file only.
7. Click **Install**. If you selected **Custom Installation** in step 5, go to step 11.
8. The **Adobe PS 8.8 Printer Driver Installer** is launched. Click **Continue**.
9. Read through the license agreement carefully and if you have no objections to it, click **Accept**.
10. Click **Install**.
11. When the installation of the AdobePS printer driver is complete, click **Quit**.
12. Click **Quit** again in the installation was successful screen. Installation is complete.

### Setting the Printer Driver (for AppleTalk Connection)

When you finish installing the AdobePS printer driver, set the PostScript Printer Description (PPD) file for this printer.

1. Make sure that the printer is on.
  2. Select the **Chooser** on the **Apple** menu, and then click **AdobePS**.
  3. Select your printer from the **Select a PostScript Printer** list box, which appears to the right of the **Chooser**, and then click **Create**.  
The program automatically searches for the printer and sets the PPD file.
-  **NOTE:** If the program does not automatically search for the PPD file, select your printer model from the dialog box that shows the PPD files to be selected.
4. To use the options, see "Configuring Settings" on page 30.

 **NOTE:** When using AppleTalk, **Installable Options** are automatically set up. You do not have to change the settings.

5. Close the Chooser.

### Setting the Printer Driver (for USB Connection)

If the printer is connected to your computer via a USB port, you will have to launch the **Desktop Printer Utility** and register the printer as a **Desktop Printer**.

1. Turn on the printer.
2. Start the **Desktop Printer Utility**.  
The **New Desktop Printer** dialog box appears.

 **NOTE:** The **Desktop Printer Utility** is located in the **AdobePS Components** folder on your Macintosh HD. If there is no **Desktop Printer Utility** in the **AdobePS Components** folder, install **Adobe PS 8.8** by using **Full Installation**.

3. Select **AdobePS** from the **With** list box, and select **Printer (USB)** from the **Create Desktop** list, then click **OK**.
4. Click **Change** under **USB Printer Selection** in the dialog box.
5. Select your printer from the list, and then click **OK**.
6. Click **Auto Setup** under **PostScript™ Printer Description (PPD) File**.  
The program automatically searches for the PPD file and displays it under the printer icon.

 **NOTE:** If the PPD file is incorrect, click **Change**, and then select the correct PPD file.

7. Click **Create** at the bottom of the dialog box.
8. Click **Save** in the dialog box confirming that the settings are saved.
9. Specify the desktop printer name and target location, then click **Save**.  
The created printer icon is displayed at the specified location.
10. To use the options, see "Configuring Settings" on page 30.

 **NOTE:** When using a USB cable, **Installable Options** are automatically set up. You do not have to change the settings. Set **Adobe Protocol** as **RAW** in **Configure-USB** from operator panel of printer.

## Setting the Printer Driver (for LPR Connection)

For the LPR connection, you will have to launch the **Desktop Printer Utility** and register the printer as a **Desktop Printer**.

1. Turn on the printer.
  2. Start your Macintosh computer and start the **Desktop Printer Utility**.  
The **New Desktop Printer** dialog box appears.
-  **NOTE:** The **Desktop Printer Utility** is located in the **AdobePS Components** folder on your Macintosh HD. If there is no **Desktop Printer Utility** in the **AdobePS Components** folder, install **Adobe PS 8.8** by using **Full Installation**.
3. Select **AdobePS** from the **With** list box, and select **Printer (LPR)** in **Create Desktop** list, then click **OK**.
  4. Click **Change** under **LPR Printer Selection** in the dialog box.
  5. Type the IP address for the printer being used in **Printer Address**, and then click **OK**.
  6. Click **Change** under **PostScript™ Printer Description (PPD) File**, and then select the correct PPD file.
  7. Click **Create** at the bottom of the dialog box.
  8. Click **Save** in the dialog box confirming that the settings are saved.
  9. Specify the desktop printer name and target location, then click **Save**.  
The created printer icon is displayed at the specified location.
  10. To use the options, see "Configuring Settings" on page 30.

## Configuring Settings

1. Click the icon of the desktop printer you created.
2. Click **Printing** on the menu bar, and select **Change Setup**.
3. Set the option menu item in **Installable Options**, and then click **OK**.

## Installing the PPD File (Mac OS X)

 **NOTE:** The printer driver does not need to be installed on a Mac OS X. It uses a generic PostScript driver that is provided with the OS.

1. Insert the *Drivers and Utilities* CD into your computer.
2. Launch the *Drivers and Utilities* CD.
3. Double-click the **Mac OS X** folder, and then double-click the **Dell 5100cn Installer** icon.
4. Type the administrator's name and password, and then click **OK**.
5. Click **Install**.
6. Click **Quit**.  
Installation is complete.
7. Go to the next section to continue.

### Adding a Printer

#### Mac OS X 10.2.8 or 10.3.X

After the PPD file has been installed, add a printer setting the PPD file.

The printer driver controls the printer functions based on the information in the PPD file.

1. Turn on the printer.
2. If you use the USB port, connect the USB cable between the printer and the Macintosh computer.
3. Start **Print Center** (or **Printer Setup Utility**). The **Printer List** screen appears.

 **NOTE:** When using Mac OS X 10.2.8, you can find **Print Center** in the **Utilities** folder in **Applications**. When using Mac OS X 10.2.8, and connecting the USB cable to your computer with the power on, the print queue, which uses a generic PPD file, is automatically created. Make sure to delete it.

 **NOTE:** When using Mac OS X 10.3.X, you can find the **Printer Setup Utility** in the **Utilities** folder in **Applications**.

4. Click **Add**.

#### When Using USB

1. Select **USB** from the menu, and then select your printer from the list.
2. For Mac OS X 10.2.8, select **Dell** from **Printer Model**.  
For Mac OS X 10.3.X, your printer model is automatically selected for **Printer Model**.
3. Click **Add**.

**When Using AppleTalk**

1. Select **AppleTalk** from the menu, and specify the zone for the printer being used.
2. Select your printer from the list.
3. Select **Auto Select** from **Printer Model**.
4. Click **Add**.

**When Using IP Printing**

1. Select **IP Printing** from the menu, and type the IP address for the printer being used in **Printer's Address**.
2. Select **Dell** from **Printer Model**, and confirm **Dell Laser Printer 5100cn** is selected for the **Model Name**. If it is not selected, select it.

 **NOTE:** When setting up of printing using IPP, a cue name is made un-inputting (You do not have to type).

3. Click **Add**.

**Configure Settings**

All the optional accessories are verified as installed.

**Mac OS 10.2.8**

1. Start **Print Center**. The **Printer List** screen appears.
2. Select the printer you want to use.
3. Click **Printers** on the **Print Center** menu bar, and select **Show Info**.
4. Select **Installable Options**, and select the options that have been installed on the printer, then click **Apply Changes**.

 **NOTE:** When using an Apple Talk, **Installable Options** are automatically set up. You do not have to change the settings.

**Mac OS 10.3.X**

1. Start **Printer Setup Utility**. The **Printer List** screen appears.
2. Select the printer you want to use.
3. Click **Printers** on the **Printer Setup Utility** menu bar, and select **Show Info**.
4. Select **Installable Options**, and select the options that have been installed on the printer, then click **Apply Changes**.

 **NOTE:** When using a USB cable and Apple Talk, **Installable Options** are automatically set up. You do not have to change the settings.



## Using Your Printer

---

Changing Printer Settings

Adjusting the Language

Printing a Job

Canceling a Job From the Printer Operator Panel

Software Overview

## Changing Printer Settings

 **NOTE:** For detailed explanations of the menus, see the *User's Guide*.

You can select menu items and corresponding values from the operator panel. When you first enter the printer menus from the operator panel, you see an asterisk (\*) next to a value in the menus. This asterisk indicates the factory default menu setting. These settings are the original printer settings. (Factory defaults may vary for different countries.) When you select a new setting from the operator panel, an asterisk appears next to the setting to identify it as the current user default menu setting. These settings are active until new ones are selected or the factory defaults are restored. To select a new value as a setting:

1. Press **Menu**.
2. Press **▲ ▼** until the required menu appears, and press **▶** or **◀**.
3. Press **▲ ▼** until the desired menu or menu item appears, and press **▶** or **◀**.
  - If the selection is a menu, the menu is opened and the first printer setting in the menu appears.
  - If the selection is a menu item, the default setting for the menu item appears. (The current user default menu setting has an asterisk (\*) beside it.)

Each menu item has a list of values for the menu item. A value can be:

- A phrase or word to describe a setting
  - A numerical value that can be changed
  - An On or Off setting
  - Press **▲ ▼** at the same time. This will recover the factory default menu settings.
4. Press **▲ ▼** to scroll until the desired value appears.
  5. Press **◀**.  
This enables the setting value, which is indicated by an asterisk (\*) next to the setting value.
  6. Press **Cancel** to return to the previous menu.

To continue setting other items, select the desired menu. To quit setting new values, press **Cancel**.

User default menu settings remain in effect until you save new settings or restore the factory defaults. Settings you choose from your software program can also change or override the user default menu settings you select from the operator panel.

 **NOTE:** Settings you choose from your software program may override the settings you select from the operator panel.

## Initializing NVRAM

You can restore the original factory default menu settings by initializing NVRAM.

1. Press **Menu**.
2. Press **▼** until **Configure** appears, and then press **▶** or **↵**.
3. Press **▼** until **Maintenance** appears, and then press **▶** or **↵**.
4. Press **▼** until **Init NVRAM** appears, and then press **▶** or **↵**.
5. The **Init NVRAM Are you sure?** message appears on the operator panel. Press **↵**.
6. Turn off the printer, and then turn it on again.

## Setting of Panel Lock

This feature prevents unauthorized personnel from changing settings made by the printer administrator. For regular printing, items can be selected from the menu and printer settings remain unchanged.

For regular printing, items can be configured using the printer driver.

1. Press **Menu**.
2. Press **▼** until **Configure** appears, and then press **▶** or **↵**.
3. Press **▼** until **Security** appears, and then press **▶** or **↵**.
4. **Panel Lock** is displayed. Press **▶** or **↵**.
5. Press **▼** until **On** appears, and then press **↵**.
6. Press **◀**.
7. Press **▼** until **Change Password** appears, and then press **▶** or **↵**.
8. Enter the old password (when you enter it for the first time after doing the settings, enter 0000), and then press **↵**.
9. Enter the new password, and then press **↵**.
10. Reenter the password to confirm the password that you entered, and then press **↵**. The password has been changed.



**NOTE:** If you forget your password, turn off the printer. Then, while holding the **Menu** button, turn on the printer. This will recover the factory default menu settings. The factory default panel password is 0000.

## Adjusting the Language

To display a different language on the operator panel:

1. Press **Menu**.
2. Press **▼** until **Configure** appears, and then press **▶** or **↵**.
3. **Basic Settings** is displayed. Press **▶** or **↵**.
4. Press **▼** until **Panel Language** appears, and then press **▶** or **↵**.
5. Press **▲ ▼** until the desired language appears, and then press **↵**.

## Printing a Job

To print a job from a Microsoft® Windows® application:

1. Open the file you want to print.
2. From the **File** menu, select **Print**.
3. Verify that the correct printer is selected in the dialog box. Modify the printer settings as appropriate (such as the pages you want to print or the number of copies).
4. Click **Properties** or **Setup** to adjust printer settings not available from the first screen, and then click **OK**.
5. Click **OK** or **Print** to send the job to the selected printer.

## Canceling a Job From the Printer Operator Panel

To cancel a print job after it has started printing:

1. Press **Cancel**.  
Printing is canceled.

## Canceling the Job From a Computer

### Canceling a Job From the Taskbar

When you send a job to print, a small printer icon appears in the right corner of the taskbar.

1. Double-click the printer icon.  
A list of print jobs appears in the printer window.
2. Select the job you want to cancel.
3. Press **<Delete>** on the keyboard.

## Canceling a Job From the Desktop

1. Minimize all programs to reveal the desktop.
2. Click **Start** → **Printers and Faxes**.  
A list of available printers appears.
3. Double-click the printer you selected.  
A list of print jobs appears in the printer window.
4. Select the job you want to cancel.
5. Press <Delete> on the keyboard.

## Software Overview

Use the *Drivers and Utilities* CD that came with your printer to install a combination of software programs, depending on your operating system.

The following software programs can only operate on Windows. They cannot operate on Macintosh, UNIX, or Linux.

### Printing Status Window

The **Printing Status Window** alerts you when an error or warning occurs, for example, when the top cover is open or toner is running low.

The **Printing Status Window** always launches when printing. When an error occurs, the error message appears on the **Printing Status Window**.

### Status Window

On the **Status Window**, you can check how much toner and paper are remaining or the configuration of options for the local printer.

### Status Monitor Console

Use the **Status Monitor Console** to manage multiple **Status Window**.

- Select a printer from the list view (or **Printer Selection**) by clicking its name to open a **Status Window** or **Dell Printer Configuration Web Tool** for a particular printer.
- Select **Help** to read the online help.
- The **Status Monitor Console** displays the **Status Window** for local connections, or the **Dell Printer Configuration Web Tool** for network connections.

## Dell Supplies Management System

You can launch the **Dell Supplies Management System** dialog box from the **Printing Status** window, the **All Programs** menu, or the desktop icon. You can also launch it from the **Status Window** when a toner error occurs.

You can order consumables by phone or from the web.

1. Click **Start** → **All Programs** → **Dell Printers** → **Dell Laser Printer 5100cn** → **Dell Supplies Management System**.

The **Dell Supplies Management System** window appears.

2. If ordering from the Web:
  - a. When you cannot get information from the printer automatically by two-way communication, a window that prompts you to type the Service Tag number appears. Type your Dell printer Service Tag number in the field provided. Your Service Tag number is located inside the front door of your printer.
  - b. Click **Visit Dell printer supplies ordering web site**.
3. If ordering by phone, call the number that appears under the **By Telephone** heading.

## User Setup Disk Creating Tool

The **User Setup Disk Creating Tool** program located in the **MakeDisk** folder of the **Utilities** folder on the *Drivers and Utilities* CD and the printer drivers located on the *Drivers and Utilities* CD are used to create driver installation packages that contain custom driver settings. A driver installation package can contain a group of saved printer driver settings and other data for things such as:

- Print orientation and Multiple Up (document settings)
- Watermarks
- Font references

If you want to install the printer driver with the same settings to multiple computers running the same operating system, create a setup disk in a floppy disk or in a server on the network. Using the setup disk that you have created will reduce the amount of work required when installing the printer driver.

- Install in advance the Dell Laser Printer 5100cn printer driver in the computer on which the setup disk is to be created.
- The setup disk can only be used on the operating system on which the disk was created or computers running the same operating system. Create a separate setup disk for different types of operating systems.

## Software Update

The firmware and/or driver updates can be downloaded from <http://www.dell.com/printers/>.

## Maintenance

---

Replacing the Imaging Drum

Replacing the Toner Cartridge

Replacing the Transfer Roller

Replacing the Fuser and Separator Roller

Cleaning the Automatic Density Control (ADC) Sensor

## Replacing the Imaging Drum

**⚠ CAUTION:** Before performing any of the following procedures, read and follow the "CAUTION: SAFETY INSTRUCTIONS" on page 9.

**⚠ CAUTION:** Never throw a used imaging drum into a fire. It could explode resulting in burns and injuries.

Dell cartridges are available only through Dell. You can order more online at <http://www.dell.com/supplies> or by phone. To order by phone, see "Order Printer Supplies" on page 2.

Dell recommends Dell cartridges for your printer. Dell does not provide warranty coverage for problems caused by using accessories, parts, or components not supplied by Dell.

### Removing the Used Imaging Drum

**✍ NOTE:** Remove any print jobs from the center output tray, and close the multipurpose feeder cover before opening the front cover.

1. Push the front latch up and fully open the front cover.

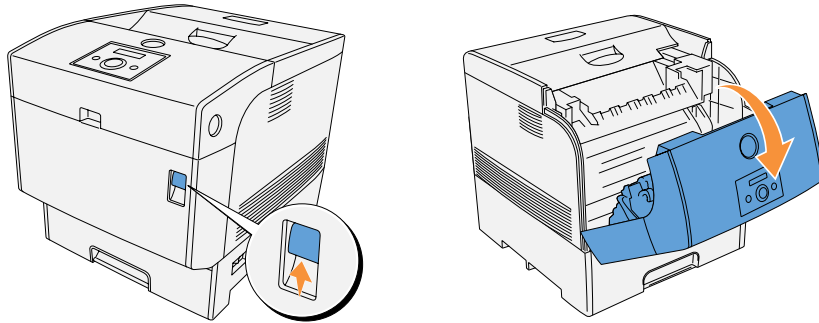

2. Push the button as shown in the following illustration and open the imaging drum cover.

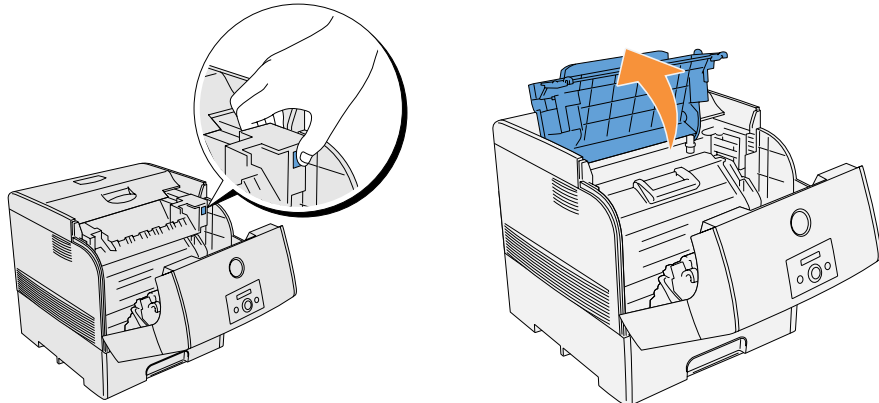



3. Grab the imaging drum by the handle, and pull it up and out.

**NOTICE:** Please put the removed imaging drum on a flat even desk without things, such as a pencil and a clip. Please cover the removed imaging drum by a newspaper or so not to expose the direct light.

**CAUTION:** Do not touch inside the printer with your hands. Some parts may be hot. Allow time for the printer to cool before attempting to remove parts in this area.

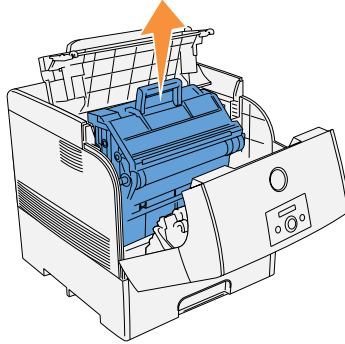

### Installing the New Imaging Drum

**CAUTION:** Make sure nothing touches or scratches the surface of the light-sensitive drum surface (green-colored roller) or the transfer roller (black-colored roller). Scratches, dirt, or oil from your hands on the imaging drum or transfer roller may reduce the print quality.

1. Remove the protective cover from the imaging drum.

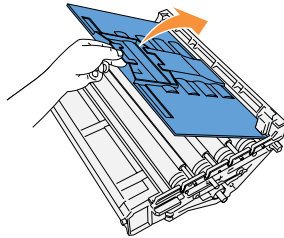

2. Holding the imaging drum by the handle with the flat part facing the back of the printer, align the plastic guides on both sides of the imaging drum with the slots in front of the arrows on the printer.

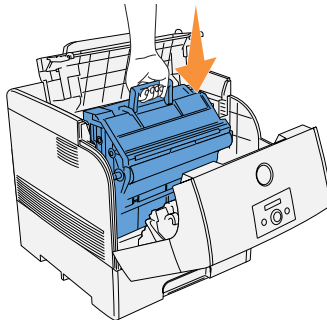

- ➔ **NOTICE:** Lowering the imaging drum into the printer without correctly aligning the rollers with the slots can damage the imaging drum.
- ➔ **NOTICE:** Do not allow the surface covered with a protective sheet to come into contact with anything.
- 3. Pull the protective cover on the imaging drum straight up to remove it.
- ➔ **NOTICE:** Do not touch the transfer roller (black-colored roller). Make sure that nothing touches or scratches the roller surface. Scratches or oil from your hands on the roller deteriorates print quality.

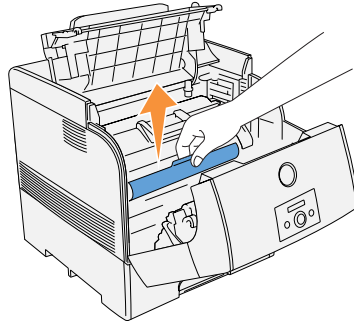

- 4. Close the imaging drum cover.

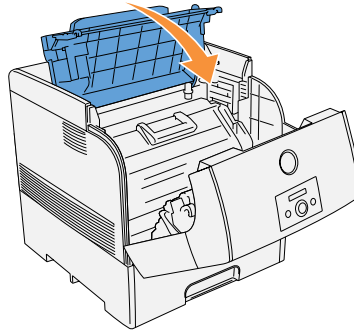

- 5. Close the front cover.

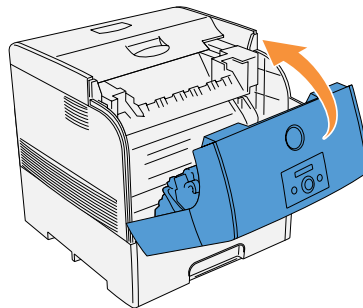

## Replacing the Toner Cartridge

**⚠ CAUTION:** Before performing any of the following procedures, read and follow the "CAUTION: SAFETY INSTRUCTIONS" on page 9.

In addition to the toner level indicator that appears each time you send a job to print, a message appears on the operator panel to alert you when it's time to order a new toner cartridge.

Dell toner cartridges are available only through Dell. You can order more toner online at <http://www.dell.com/supplies> or by phone. To order by phone, see "Order Printer Supplies" on page 2.

Dell recommends Dell-branded toner cartridges for your printer. Dell does not provide warranty coverage for problems caused by using accessories, parts, or components not supplied by Dell.

**⚠ CAUTION:** Never throw used toner cartridges into a fire. The residual toner could explode resulting in burns and injuries.

### Removing the Used Toner Cartridge

**✍ NOTE:** Remove any print jobs from the outer front cover before removing the top cover.

1. Remove the top cover.

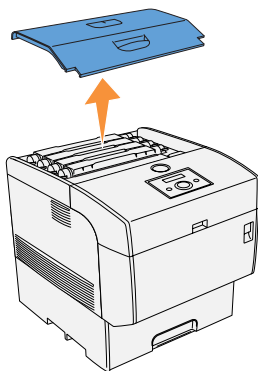

2. Grip the levers at the ends of the toner cartridge that you want to replace and then rotate them to the up position.

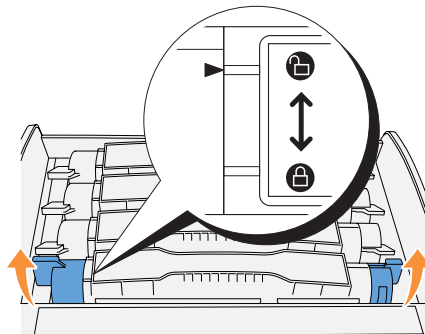

3. Pull out the toner cartridge.

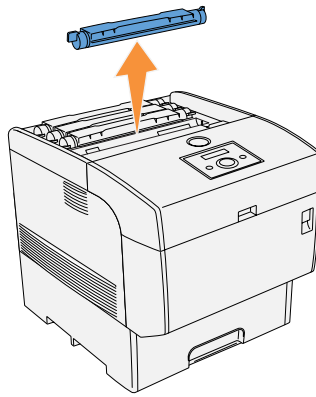

### Installing the New Toner Cartridge

1. Select the new toner cartridge whose color matches the cartridge carrier and remove it from its packaging.

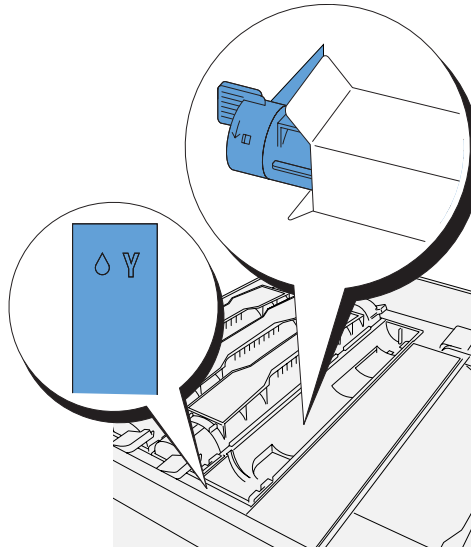

2. Gently shake the cartridge to distribute the toner evenly.

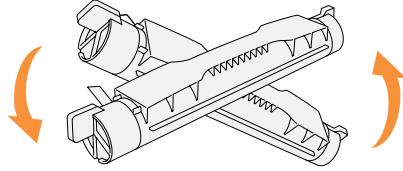

3. Align the toner cartridge with the corresponding cartridge carrier in the printer and insert it.

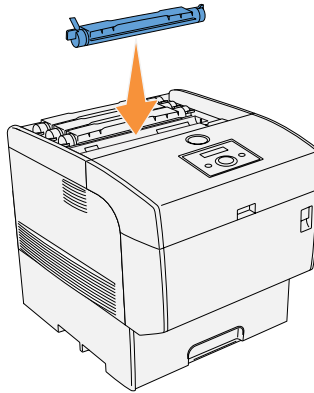

4. Grip the levers at each end of the toner cartridge, then push down firmly to rotate the levers forward.

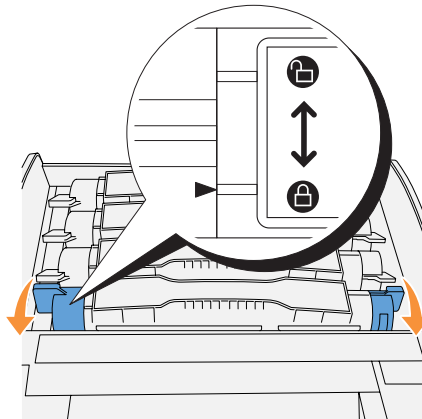

5. Pull the toner seal straight up to remove it.



**NOTE:** Pull the toner seal straight up. Pulling the toner seal diagonally may tear the seal.



**NOTE:** If it takes more than five seconds to remove the toner seal after inserting the toner cartridge in the printer, an error message may appear. In this case, perform step 4 again, or turn the printer off once and then on again.

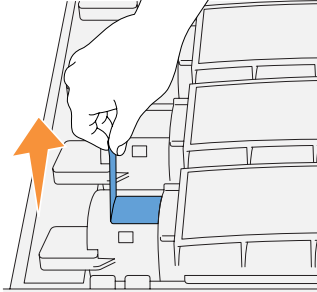

6. Replace the top cover by inserting its front side into the printer first.

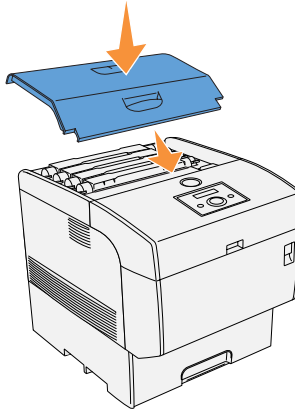

## Replacing the Transfer Roller

**CAUTION:** Before performing any of the following procedures, read and follow the "CAUTION: SAFETY INSTRUCTIONS" on page 9.

Dell transfer roller are available only through Dell. You can order more online at <http://www.dell.com/supplies> or by phone. To order by phone, see "Order Printer Supplies" on page 2.

Dell recommends Dell transfer roller for your printer. Dell does not provide warranty coverage for problems caused by using accessories, parts, or components not supplied by Dell.

### Removing the Used Transfer Roller

**CAUTION:** Never throw a used transfer roller into a fire. It could explode resulting in burns and injuries.

**CAUTION:** Do not touch the edge of the plate at the upper side of the transfer roller because it is sharp.

**NOTE:** Remove any print jobs from the center output tray, and close the multipurpose feeder cover before opening the front cover.

1. Push the front latch up and fully open the front cover.

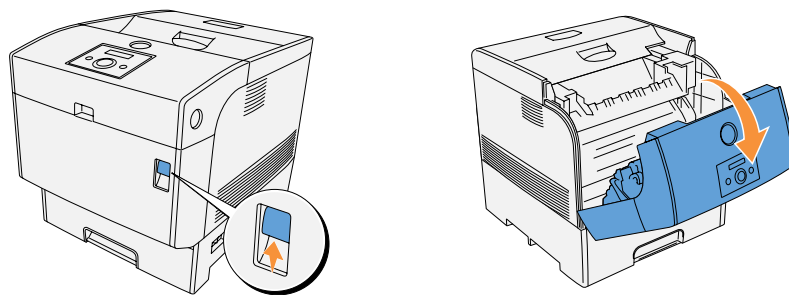

2. Grip the tabs at both ends of the transfer roller and gently lift it out of the printer.

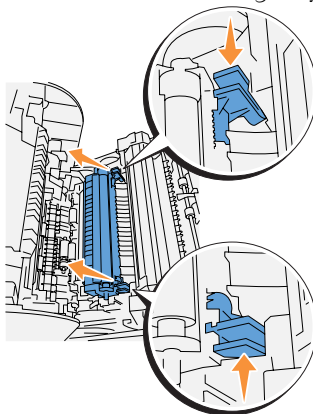

## Installing the New Transfer Roller

1. Unpack a new transfer roller and grip the tabs as shown.

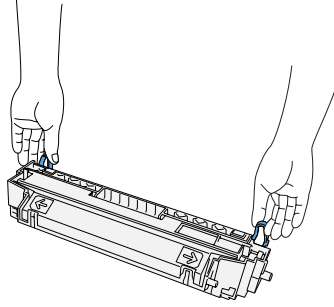

2. Align the arrow marks on the transfer roller to the marks on the printer, and gently push the roller into the printer.

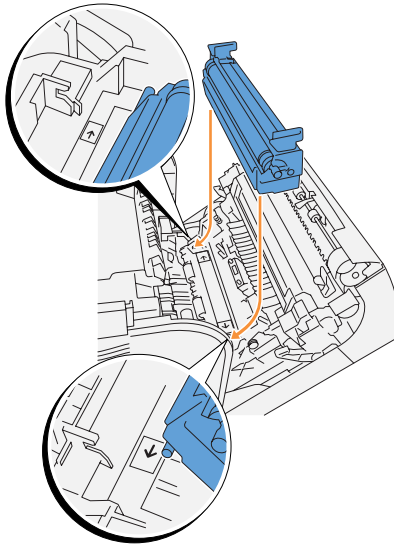



3. To lock the transfer roller into the printer, push down the tabs until you hear a click.

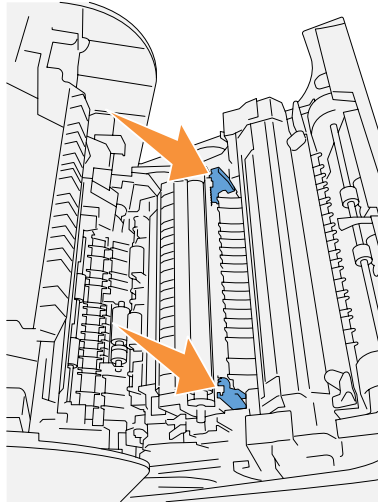

4. Close the front cover.

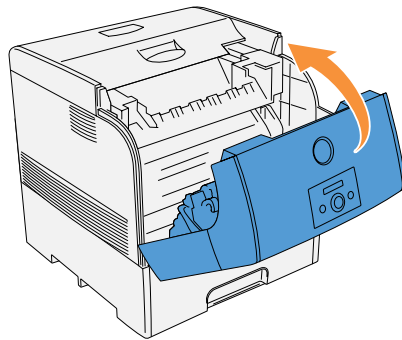

## Replacing the Fuser and Separator Roller

To avoid burns, do not replace the fuser immediately after printing, as the fuser gets very hot during this process.

**⚠ CAUTION:** To avoid burns, never touch the fuser until at least 30 minutes after you have turned off the printer.

**⚠ CAUTION:** Before performing any of the following procedures, read and follow the "CAUTION: SAFETY INSTRUCTIONS" on page 9.

Dell fuser are available only through Dell. You can order more online at <http://www.dell.com/supplies> or by phone. To order by phone, see "Order Printer Supplies" on page 2.

Dell recommends Dell fuser for your printer. Dell does not provide warranty coverage for problems caused by using accessories, parts, or components not supplied by Dell.

### Removing the Used Fuser

**✍ NOTE:** Remove any print jobs from the center output tray, and close the multipurpose feeder cover before opening the outer front cover.

1. Turn off the printer and wait for 30 minutes.
2. Push the side button and open the outer front cover.

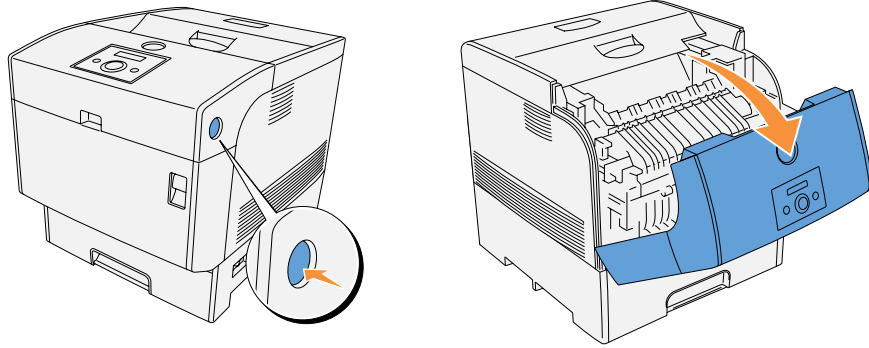

3. Lift up the levers next to both ends of the fuser.

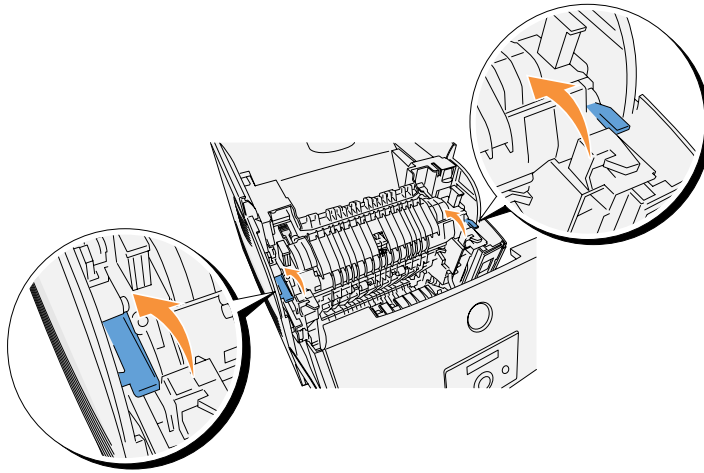

4. Grip the knobs and gently lift the fuser out of the printer.

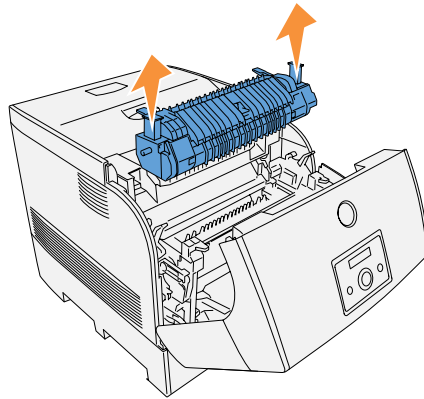

## Installing the New Fuser

1. Unpack a new fuser, grip the fuser by the knobs, align it with the slots in the printer, and slowly push it in.

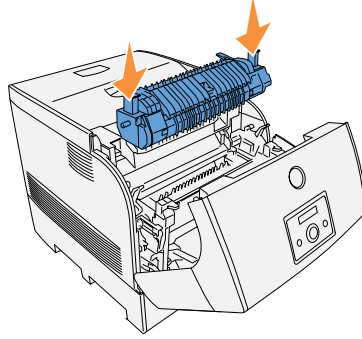

2. Completely push down the fuser by holding the knobs at both ends of the fuser until the levers next to both ends of the fuser return to their original position.

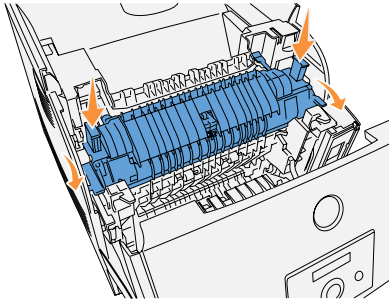

3. Close the outer front cover.

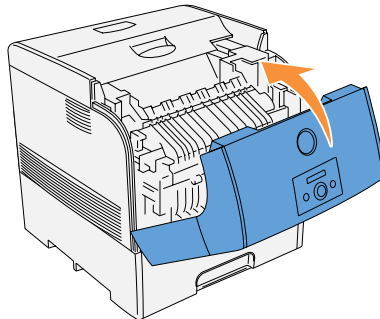

## Removing the Used Separator Roller

 **NOTE:** Remove any print jobs from the tray before pulling the tray out of the printer.

1. Pull the tray out of the printer until it stops. Hold the tray with both hands, lift the front slightly, and remove it from the printer.

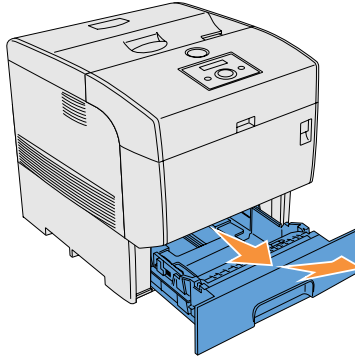

2. Press both tabs inward and hold while gently lifting the separator roller cover to the open position.

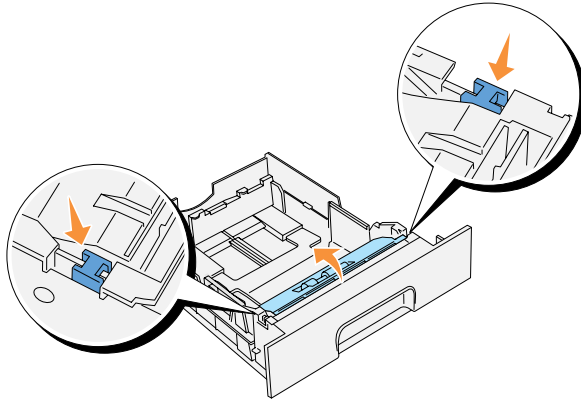

3. Gently raise the separator roller assembly, and slide it to the left.

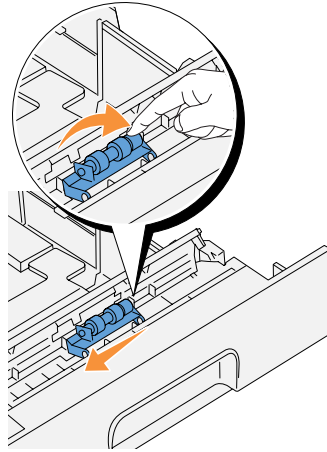

### Installing the New Separator Roller

1. Align the holes of the new separator roller with the projections in the tray and slide the separator roller until it stops. Then, release your hand from the separator roller.

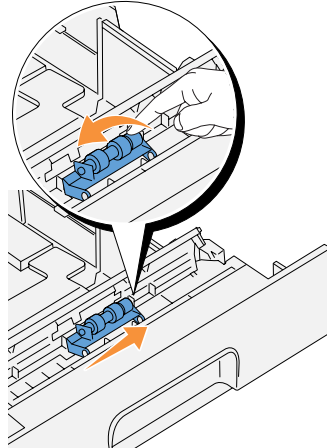

2. Close the separator roller cover.

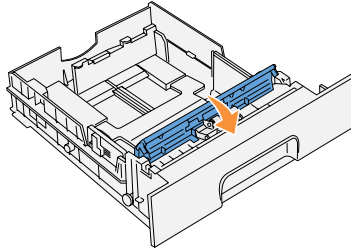

3. Replace the printer's tray into the printer.

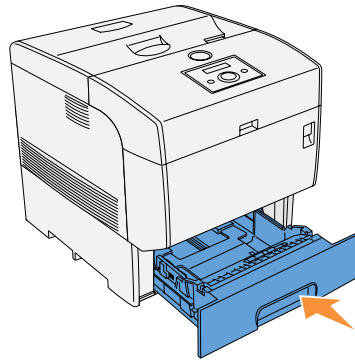

## Cleaning the Automatic Density Control (ADC) Sensor

**⚠ CAUTION:** Before performing any of the following procedures, read and follow the "CAUTION: SAFETY INSTRUCTIONS" on page 9.

When the printer's automatic density control (ADC) sensor is dirty, follow the procedure below to clean it.

1. Turn off the printer.
2. Push the front latch and fully open the front cover.

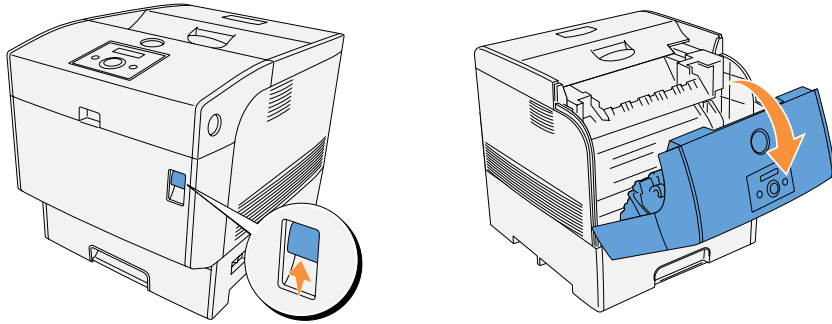

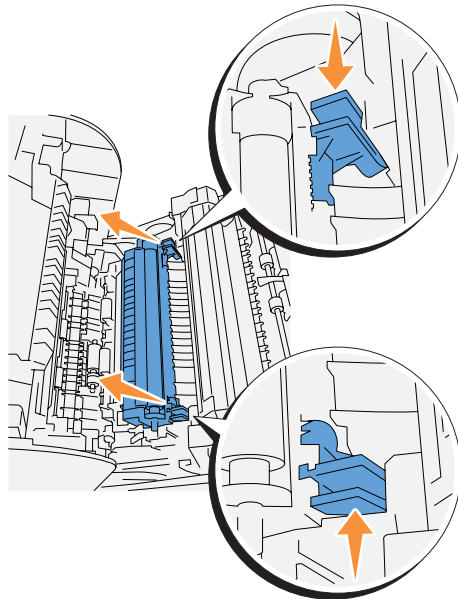

3. Grip the tabs at both ends of the transfer roller and gently lift it out of the printer.



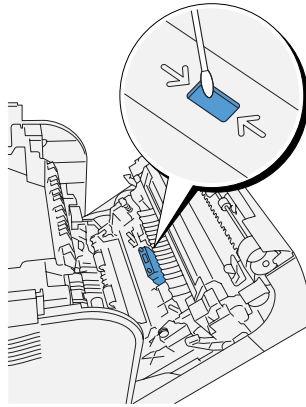

4. Gently wipe the automatic density control (ADC) sensor window with a clean dry cloth or cotton swab.



 **NOTE:** Do not allow anything hard to come in contact with the automatic density control (ADC) sensor window. Do not use excessive force to clean the window.

5. Replace the transfer roller. Grip the tabs as shown.

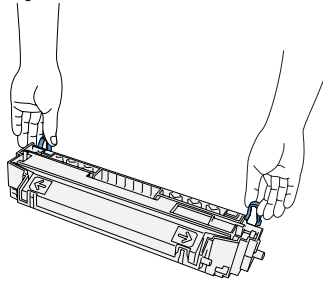

6. Align the arrow marks on the transfer roller to the marks on the printer, and gently push the roller into the printer.

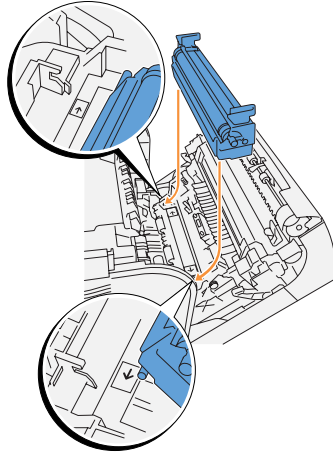

7. To lock the transfer roller into the printer, push down the tabs until you hear a click.

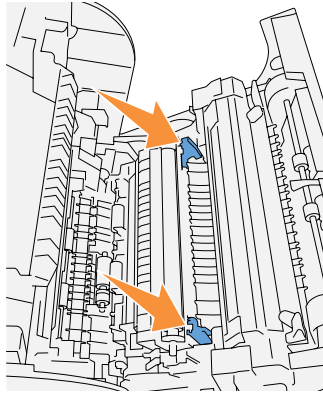

8. Close the front cover.

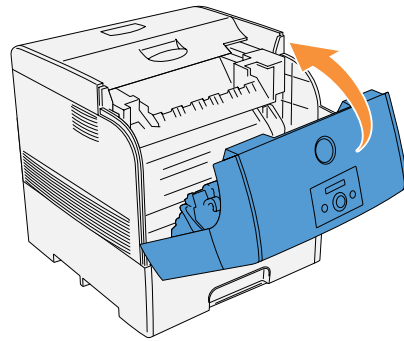

9. Turn on the printer.



# Appendix

---

Technical Assistance

Automated Order-Status Service

Contacting Dell

U.S. Terms and Conditions of Sale

Limited Warranties and Return Policy

Dell Inc. Ink and Toner Cartridges Limited Warranties

Dell™ Software License Agreement

Regulatory

## Technical Assistance

If you need help with a technical problem, Dell is ready to assist you.

1. Call technical support from a telephone near or at the printer so that technical support can assist you with any necessary procedures. When calling Dell, use your Express Service Code to help expedite the routing of your call to the proper support personnel.

The Express Service Code is located on the printer as shown below.

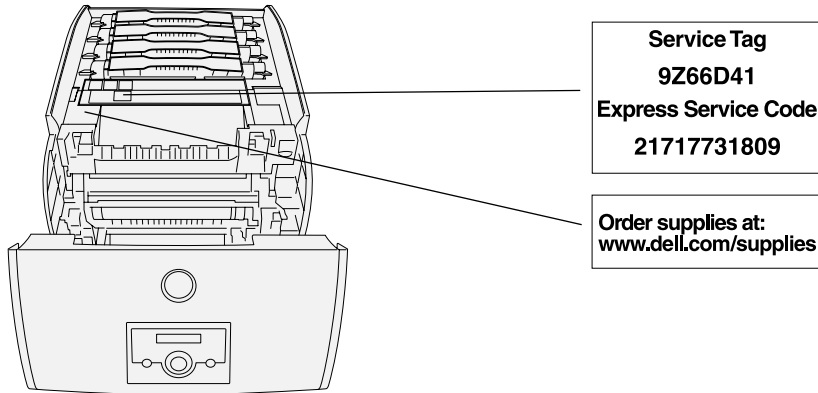

**NOTE:** Dell's Express Service Code system may not be available in all countries.

2. In the U.S., Business customers should call 1-877-459-7298, and Consumer (Home and Home Office) customers should call 1-800-624-9896.

If you are calling from a different country or are in a different Service area, see "Contacting Dell" on page 63 for your local telephone number.

3. Follow the menu prompts in the automated telephone system to speak with a technical support representative.

## Automated Order-Status Service

To check on the status of any Dell™ products that you have ordered, you can go to [support.dell.com](http://support.dell.com), or you can call the automated order-status service. A recording prompts you for the information needed to locate and report on your order. See "Contacting Dell" on page 63 for the telephone number to call for your region.

## Contacting Dell

To contact Dell electronically, you can access the following websites:

- [www.dell.com](http://www.dell.com)
- [support.dell.com](http://support.dell.com) (technical support)
- [premiersupport.dell.com](http://premiersupport.dell.com) (technical support for educational, government, healthcare, and medium/large business customers, including Premier, Platinum, and Gold customers)

For specific web addresses for your country, find the appropriate country section in the table below.



**NOTE:** Toll-free numbers are for use within the country for which they are listed.

When you need to contact Dell, use the electronic addresses, telephone numbers, and codes provided in the following table. If you need assistance in determining which codes to use, contact a local or an international operator.

<b>Country (City) International Access Code Country Code City Code</b>	<b>Department Name or Service Area, Website and E-Mail Address</b>	<b>Area Codes, Local Numbers, and Toll-Free Numbers</b>
Anguilla	General Support	toll-free: 800-335-0031
Antigua and Barbuda	General Support	1-800-805-5924
Argentina (Buenos Aires)	Website: <a href="http://www.dell.com.ar">www.dell.com.ar</a>	
International Access Code: 00	E-mail: <a href="mailto:us_latin_services@dell.com">us_latin_services@dell.com</a>	
Country Code: 54	E-mail for desktop and portable computers: <a href="mailto:la-techsupport@dell.com">la-techsupport@dell.com</a>	
City Code: 11	E-mail for servers and EMC: <a href="mailto:la_enterprise@dell.com">la_enterprise@dell.com</a>	
	Customer Care	toll-free: 0-800-444-0730
	Tech Support	toll-free: 0-800-444-0733
	Tech Support Services	toll-free: 0-800-444-0724
	Sales	0-810-444-3355
Aruba	General Support	toll-free: 800-1578

<b>Country (City) International Access Code Country Code City Code</b>	<b>Department Name or Service Area, Website and E-Mail Address</b>	<b>Area Codes, Local Numbers, and Toll-Free Numbers</b>
Australia (Sydney)	E-mail (Australia): au_tech_support@dell.com	
International Access Code: 0011	E-mail (New Zealand): nz_tech_support@dell.com	
Country Code: 61	Home and Small Business	1-300-65-55-33
City Code: 2	Government and Business	toll-free: 1-800-633-559
	Preferred Accounts Division (PAD)	toll-free: 1-800-060-889
	For servers and storage	toll-free: 1-800-505-095
	For desktop and portable computers	toll-free: 1-800-733-314
	Customer Care	toll-free: 1-800-819-339
	Corporate Sales	toll-free: 1-800-808-385
	Transaction Sales	toll-free: 1-800-808-312
	Fax	toll-free: 1-800-818-341
Austria (Vienna)	Website: support.euro.dell.com	
International Access Code: 900	E-mail: tech_support_central_europe@dell.com	
Country Code: 43	Home/Small Business Sales	0820 240 530 00
City Code: 1	Home/Small Business Fax	0820 240 530 49
	Home/Small Business Customer Care	0820 240 530 14
	Preferred Accounts/Corporate Customer Care	0820 240 530 16
	Home/Small Business Technical Support	0820 240 530 14
	Preferred Accounts/Corporate Technical Support	0660 8779
	Switchboard	0820 240 530 00
Bahamas	General Support	toll-free: 1-866-278-6818
Barbados	General Support	1-800-534-3066
Belgium (Brussels)	Website: support.euro.dell.com	
International Access Code: 00	E-mail for French Speaking Customers: support.euro.dell.com/be/fr/emaildell/	
Country Code: 32	Technical Support	02 481 92 88
City Code: 2	Technical Support Fax	02 481 92 95
	Customer Care	02 713 15 .65
	Corporate Sales	02 481 91 00
	Fax	02 481 92 99
	Switchboard	02 481 91 00



<b>Country (City) International Access Code Country Code City Code</b>	<b>Department Name or Service Area, Website and E-Mail Address</b>	<b>Area Codes, Local Numbers, and Toll-Free Numbers</b>
Bermuda	General Support	1-800-342-0671
Bolivia	General Support	toll-free: 800-10-0238
<b>Brazil</b>	Website: <a href="http://www.dell.com/br">www.dell.com/br</a>	
International Access Code: 00	Customer Support, Technical Support	0800 90 3355
Country Code: 55	Technical Support Fax	51 481 5470
City Code: 51	Customer Care Fax	51 481 5480
	Sales	0800 90 3390
<b>British Virgin Islands</b>	General Support	toll-free: 1-866-278-6820
<b>Brunei</b>	Customer Technical Support (Penang, Malaysia)	604 633 4966
Country Code: 673	Customer Service (Penang, Malaysia)	604 633 4949
	Transaction Sales (Penang, Malaysia)	604 633 4955
<b>Canada (North York, Ontario)</b>	Online Order Status: <a href="http://www.dell.ca/ostatus">www.dell.ca/ostatus</a>	
International Access Code: 011	AutoTech (automated technical support)	toll-free: 1-800-247-9362
	Customer Care (Home Sales/Small Business)	toll-free: 1-800-847-4096
	Customer Care (med./large business, government)	toll-free: 1-800-326-9463
	Technical Support (Home Sales/Small Business)	toll-free: 1-800-847-4096
	Technical Support (med./large bus., government)	toll-free: 1-800-387-5757
	Sales (Home Sales/Small Business)	toll-free: 1-800-387-5752
	Sales (med./large bus., government)	toll-free: 1-800-387-5755
	Spare Parts Sales & Extended Service Sales	1 866 440 3355
<b>Cayman Islands</b>	General Support	1-800-805-7541
<b>Chile (Santiago)</b>	Sales, Customer Support, and Technical Support	toll-free: 1230-020-4823
Country Code: 56		
City Code: 2		

<b>Country (City) International Access Code Country Code City Code</b>	<b>Department Name or Service Area, Website and E-Mail Address</b>	<b>Area Codes, Local Numbers, and Toll-Free Numbers</b>
China (Xiamen) Country Code: 86 City Code: 592	Technical Support website: <a href="http://support.dell.com.cn">support.dell.com.cn</a> Technical Support E-mail: <a href="mailto:cn_support@dell.com">cn_support@dell.com</a> Technical Support Fax Technical Support (Dimension™ and Inspiron™) Technical Support (OptiPlex™, Latitude™, and Dell Precision™) Technical Support (servers and storage) Technical Support (projectors, PDAs, printers, switches, routers, and so on) Customer Advocacy Customer Advocacy Fax Home and Small Business Preferred Accounts Division Large Corporate Accounts GCP Large Corporate Accounts Key Accounts Large Corporate Accounts North Large Corporate Accounts North Government and Education Large Corporate Accounts East Large Corporate Accounts East Government and Education Large Corporate Accounts Queue Team Large Corporate Accounts South Large Corporate Accounts West Large Corporate Accounts Spare Parts	818 1350 toll-free: 800 858 2969 toll-free: 800 858 0950 toll-free: 800 858 0960 toll-free: 800 858 2920 toll-free: 800 858 2060 592 818 1308 toll-free: 800 858 2222 toll-free: 800 858 2557 toll-free: 800 858 2055 toll-free: 800 858 2628 toll-free: 800 858 2999 toll-free: 800 858 2955 toll-free: 800 858 2020 toll-free: 800 858 2669 toll-free: 800 858 2572 toll-free: 800 858 2355 toll-free: 800 858 2811 toll-free: 800 858 2621
Colombia	General Support	980-9-15-3978
Costa Rica	General Support	0800-012-0435

<b>Country (City) International Access Code Country Code City Code</b>	<b>Department Name or Service Area, Website and E-Mail Address</b>	<b>Area Codes, Local Numbers, and Toll-Free Numbers</b>
Czech Republic (Prague)	Website: support.euro.dell.com	
International Access Code: 00	E-mail: czech_dell@dell.com	
Country Code: 420	Technical Support	02 2186 27 27
City Code: 2	Technical Support Fax	02 2186 27 28
	Customer Care	02 2186 27 11
	Customer Care Fax	02 2186 27 14
	Switchboard	02 2186 27 11
Denmark (Copenhagen)	Website: support.euro.dell.com	
International Access Code: 00	E-mail Support (portable computers): den_nbk_support@dell.com	
Country Code: 45	E-mail Support (desktop computers): den_support@dell.com	
	E-mail Support (servers): Nordic_server_support@dell.com	
	Technical Support	7023 0182
	Customer Care (Relational)	7023 0184
	Home/Small Business Customer Care	3287 5505
	Switchboard (Relational)	3287 1200
	Switchboard Fax (Relational)	3287 1201
	Switchboard (Home/Small Business)	3287 5000
	Switchboard Fax (Home/Small Business)	3287 5001
Dominica	General Support	toll-free: 1-866-278-6821
Dominican Republic	General Support	1-800-148-0530
Ecuador	General Support	toll-free: 999-119
El Salvador	General Support	01-899-753-0777

<b>Country (City) International Access Code Country Code City Code</b>	<b>Department Name or Service Area, Website and E-Mail Address</b>	<b>Area Codes, Local Numbers, and Toll-Free Numbers</b>
Finland (Helsinki)	Website: support.euro.dell.com	
International Access Code: 990	E-mail: fin_support@dell.com	
Country Code: 358	E-mail Support (servers): Nordic_support@dell.com	
City Code: 9	Technical Support	09 253 313 60
	Technical Support Fax	09 253 313 81
	Relational Customer Care	09 253 313 38
	Home/Small Business Customer Care	09 693 791 94
	Fax	09 253 313 99
	Switchboard	09 253 313 00
France (Paris) (Montpellier)	Website: support.euro.dell.com	
International Access Code: 00	E-mail: support.euro.dell.com/fr/fr/emaildell/	
Country Code: 33	<b>Home and Small Business</b>	
City Codes: (1) (4)	Technical Support	0825 387 270
	Customer Care	0825 823 833
	Switchboard	0825 004 700
	Switchboard (calls from outside of France)	04 99 75 40 00
	Sales	0825 004 700
	Fax	0825 004 701
	Fax (calls from outside of France)	04 99 75 40 01
	<b>Corporate</b>	
	Technical Support	0825 004 719
	Customer Care	0825 338 339
	Switchboard	01 55 94 71 00
	Sales	01 55 94 71 00
	Fax	01 55 94 71 01

<b>Country (City) International Access Code Country Code City Code</b>	<b>Department Name or Service Area, Website and E-Mail Address</b>	<b>Area Codes, Local Numbers, and Toll-Free Numbers</b>
Germany (Langen) International Access Code: 00 Country Code: 49 City Code: 6103	Website: <a href="http://support.euro.dell.com">support.euro.dell.com</a> E-mail: <a href="mailto:tech_support_central_europe@dell.com">tech_support_central_europe@dell.com</a> Technical Support Home/Small Business Customer Care Global Segment Customer Care Preferred Accounts Customer Care Large Accounts Customer Care Public Accounts Customer Care Switchboard	06103 766-7200 0180-5-224400 06103 766-9570 06103 766-9420 06103 766-9560 06103 766-9555 06103 766-7000
Greece International Access Code: 00 Country Code: 30	Website: <a href="http://support.euro.dell.com">support.euro.dell.com</a> E-mail: <a href="mailto:support.euro.dell.com/gr/en/emaildell/">support.euro.dell.com/gr/en/emaildell/</a> Technical Support Gold Service Technical Support Switchboard Gold Service Switchboard Sales Fax	00800-44 14 95 18 00800-44 14 00 83 2108129810 2108129811 2108129800 2108129812
Grenada	General Support	toll-free: 1-866-540-3355
Guatemala	General Support	1-800-999-0136
Guyana	General Support	toll-free: 1-877-270-4609
Hong Kong International Access Code: 001 Country Code: 852	Website: <a href="http://support.ap.dell.com">support.ap.dell.com</a> E-mail: <a href="mailto:apsupport@dell.com">apsupport@dell.com</a> Technical Support (Dimension™ and Inspiron™) Technical Support (OptiPlex™, Latitude™, and Dell Precision™) Technical Support (PowerApp™, PowerEdge™, PowerConnect™, and PowerVault™) Gold Queue EEC Hotline Customer Advocacy Large Corporate Accounts Global Customer Programs Medium Business Division	2969 3188 2969 3191 2969 3196 2969 3187 3416 0910 3416 0907 3416 0908 3416 0912

<b>Country (City) International Access Code Country Code City Code</b>	<b>Department Name or Service Area, Website and E-Mail Address</b>	<b>Area Codes, Local Numbers, and Toll-Free Numbers</b>
	Home and Small Business Division	2969 3155
<b>India</b>	Technical Support	1600 33 8045
	Sales	1600 33 8044
<b>Ireland (Cherrywood)</b>	Website: <a href="http://support.euro.dell.com">support.euro.dell.com</a>	
International Access Code: 16	E-mail: <a href="mailto:dell_direct_support@dell.com">dell_direct_support@dell.com</a>	
Country Code: 353	Technical Support	1850 543 543
City Code: 1	U.K. Technical Support (dial within U.K. only)	0870 908 0800
	Home User Customer Care	01 204 4014
	Small Business Customer Care	01 204 4014
	U.K. Customer Care (dial within U.K. only)	0870 906 0010
	Corporate Customer Care	1850 200 982
	Corporate Customer Care (dial within U.K. only)	0870 907 4499
	Ireland Sales	01 204 4444
	U.K. Sales (dial within U.K. only)	0870 907 4000
	Fax/Sales Fax	01 204 0103
	Switchboard	01 204 4444
<b>Italy (Milan)</b>	Website: <a href="http://support.euro.dell.com">support.euro.dell.com</a>	
International Access Code: 00	E-mail: <a href="http://support.euro.dell.com/it/it/emaildell/">support.euro.dell.com/it/it/emaildell/</a>	
Country Code: 39	<b>Home and Small Business</b>	
City Code: 02	Technical Support	02 577 826 90
	Customer Care	02 696 821 14
	Fax	02 696 821 13
	Switchboard	02 696 821 12
	<b>Corporate</b>	
	Technical Support	02 577 826 90
	Customer Care	02 577 825 55
	Fax	02 575 035 30
	Switchboard	02 577 821
<b>Jamaica</b>	General Support (dial from within Jamaica only)	1-800-682-3639

<b>Country (City) International Access Code Country Code City Code</b>	<b>Department Name or Service Area, Website and E-Mail Address</b>	<b>Area Codes, Local Numbers, and Toll-Free Numbers</b>
Japan (Kawasaki)	Website: support.jp.dell.com	
International Access Code: 001	Technical Support (servers)	toll-free: 0120-198-498
Country Code: 81	Technical Support outside of Japan (servers)	81-44-556-4162
City Code: 44	Technical Support (Dimension™ and Inspiron™)	toll-free: 0120-198-226
	Technical Support outside of Japan (Dimension and Inspiron)	81-44-520-1435
	Technical Support (Dell Precision™, OptiPlex™, and Latitude™)	toll-free:0120-198-433
	Technical Support outside of Japan (Dell Precision, OptiPlex, and Latitude)	81-44-556-3894
	Technical Support (PDAs, projectors, printers, routers)	toll-free: 0120-981-690
	Technical Support outside of Japan (PDAs, projectors, printers, routers)	81-44-556-3468
	Faxbox Service	044-556-3490
	24-Hour Automated Order Service	044-556-3801
	Customer Care	044-556-4240
	Business Sales Division (up to 400 employees)	044-556-1465
	Preferred Accounts Division Sales (over 400 employees)	044-556-3433
	Large Corporate Accounts Sales (over 3500 employees)	044-556-3430
	Public Sales (government agencies, educational institutions, and medical institutions)	044-556-1469
	Global Segment Japan	044-556-3469
	Individual User	044-556-1760
	Switchboard	044-556-4300
<b>Korea (Seoul)</b>	Technical Support	toll-free: 080-200-3800
International Access Code: 001	Sales	toll-free: 080-200-3600
Country Code: 82	Customer Service (Seoul, Korea)	toll-free: 080-200-3800
City Code: 2	Customer Service (Penang, Malaysia)	604 633 4949
	Fax	2194-6202
	Switchboard	2194-6000

<b>Country (City) International Access Code Country Code City Code</b>	<b>Department Name or Service Area, Website and E-Mail Address</b>	<b>Area Codes, Local Numbers, and Toll-Free Numbers</b>
<b>Latin America</b>	Customer Technical Support (Austin, Texas, U.S.A.)	512 728-4093
	Customer Service (Austin, Texas, U.S.A.)	512 728-3619
	Fax (Technical Support and Customer Service) (Austin, Texas, U.S.A.)	512 728-3883
	Sales (Austin, Texas, U.S.A.)	512 728-4397
	SalesFax (Austin, Texas, U.S.A.)	512 728-4600 or 512 728-3772
<b>Luxembourg</b>	Website: <a href="http://support.euro.dell.com">support.euro.dell.com</a>	
International Access Code: 00	E-mail: <a href="mailto:tech_be@dell.com">tech_be@dell.com</a>	
Country Code: 352	Technical Support (Brussels, Belgium)	3420808075
	Home/Small Business Sales (Brussels, Belgium)	toll-free: 080016884
	Corporate Sales (Brussels, Belgium)	02 481 91 00
	Customer Care (Brussels, Belgium)	02 481 91 19
	Fax (Brussels, Belgium)	02 481 92 99
	Switchboard (Brussels, Belgium)	02 481 91 00
<b>Macao</b>	Technical Support	toll-free: 0800 582
Country Code: 853	Customer Service (Penang, Malaysia)	604 633 4949
	Transaction Sales	toll-free: 0800 581
<b>Malaysia (Penang)</b>	Technical Support (Dell Precision, OptiPlex, and Latitude)	toll-free: 1 800 88 0193
International Access Code: 00		
Country Code: 60	Technical Support (Dimension and Inspiron)	toll-free: 1 800 88 1306
City Code: 4	Technical Support (PowerEdge and PowerVault)	toll-free: 1800 88 1386
	Customer Service	04 633 4949
	Transaction Sales	toll-free: 1 800 888 202
	Corporate Sales	toll-free: 1 800 888 213



<b>Country (City) International Access Code Country Code City Code</b>	<b>Department Name or Service Area, Website and E-Mail Address</b>	<b>Area Codes, Local Numbers, and Toll-Free Numbers</b>
Mexico	Customer Technical Support	001-877-384-8979
International Access Code: 00		or 001-877-269-3383
Country Code: 52	Sales	50-81-8800
		or 01-800-888-3355
	Customer Service	001-877-384-8979
		or 001-877-269-3383
	Main	50-81-8800
		or 01-800-888-3355
Montserrat	General Support	toll-free: 1-866-278-6822
Netherlands Antilles	General Support	001-800-882-1519
Netherlands (Amsterdam)	Website: <a href="http://support.euro.dell.com">support.euro.dell.com</a>	
International Access Code: 00	Technical Support	020 674 45 00
Country Code: 31	Technical Support Fax	020 674 47 66
City Code: 20	Home/Small Business Customer Care	020 674 42 00
	Relational Customer Care	020 674 4325
	Home/Small Business Sales	020 674 55 00
	Relational Sales	020 674 50 00
	Home/Small Business Sales Fax	020 674 47 75
	Relational Sales Fax	020 674 47 50
	Switchboard	020 674 50 00
	Switchboard Fax	020 674 47 50
New Zealand	E-mail (New Zealand): <a href="mailto:nz_tech_support@dell.com">nz_tech_support@dell.com</a>	
International Access Code: 00	E-mail (Australia): <a href="mailto:au_tech_support@dell.com">au_tech_support@dell.com</a>	
Country Code: 64	Technical Support (for desktop and portable computers)	0800 443 563
	Technical Support (for servers and storage)	0800 505 098
	Home and Small Business	0800 446 255
	Government and Business	0800 444 617
	Sales	0800 441 567
	Fax	0800 441 566
Nicaragua	General Support	001-800-220-1006

<b>Country (City) International Access Code Country Code City Code</b>	<b>Department Name or Service Area, Website and E-Mail Address</b>	<b>Area Codes, Local Numbers, and Toll-Free Numbers</b>
Norway (Lysaker)	Website: <a href="http://support.euro.dell.com">support.euro.dell.com</a>	
International Access Code: 00	E-mail Support (portable computers):	
Country Code: 47	<a href="mailto:nor_nbk_support@dell.com">nor_nbk_support@dell.com</a>	
	E-mail Support (desktop computers):	
	<a href="mailto:nor_support@dell.com">nor_support@dell.com</a>	
	E-mail Support (servers):	
	<a href="mailto:nordic_server_support@dell.com">nordic_server_support@dell.com</a>	
	Technical Support	671 16882
	Relational Customer Care	671 17514
	Home/Small Business Customer Care	23162298
	Switchboard	671 16800
	Fax Switchboard	671 16865
<b>Panama</b>	General Support	001-800-507-0962
<b>Peru</b>	General Support	0800-50-669
<b>Poland (Warsaw)</b>	Website: <a href="http://support.euro.dell.com">support.euro.dell.com</a>	
International Access Code: 011	E-mail: <a href="mailto:pl_support_tech@dell.com">pl_support_tech@dell.com</a>	
Country Code: 48	Customer Service Phone	57 95 700
City Code: 22	Customer Care	57 95 999
	Sales	57 95 999
	Customer Service Fax	57 95 806
	Reception Desk Fax	57 95 998
	Switchboard	57 95 999
<b>Portugal</b>	Website: <a href="http://support.euro.dell.com">support.euro.dell.com</a>	
International Access Code: 00	E-mail: <a href="http://support.euro.dell.com/pt/en/emailldell/">support.euro.dell.com/pt/en/emailldell/</a>	
Country Code: 351	Technical Support	707200149
	Customer Care	800 300 413
	Sales	800 300 410 or 800 300 411 or 800 300 412 or 21 422 07 10
	Fax	21 424 01 12
<b>Puerto Rico</b>	General Support	1-800-805-7545
<b>St. Kitts and Nevis</b>	General Support	toll-free: 1-877-441-4731

<b>Country (City) International Access Code Country Code City Code</b>	<b>Department Name or Service Area, Website and E-Mail Address</b>	<b>Area Codes, Local Numbers, and Toll-Free Numbers</b>
St. Lucia	General Support	1-800-882-1521
St. Vincent and the Grenadines	General Support	toll-free: 1-877-270-4609
Singapore (Singapore)	Technical Support (Dimension and Inspiron)	toll-free: 1800 394 7430
International Access Code: 005 Country Code: 65	Technical Support (Optiplex, Latitude, and Precision)	toll-free: 1800 394 7488
	Technical Support (PowerEdge and PowerVault)	toll-free: 1800 394 7478
	Customer Service (Penang, Malaysia)	604 633 4949
	Transaction Sales	toll-free: 800 6011 054
	Corporate Sales	toll-free: 800 6011 053
<b>South Africa (Johannesburg)</b>	Website: <a href="http://support.euro.dell.com">support.euro.dell.com</a>	
International Access Code: 09/091	E-mail: <a href="mailto:dell_za_support@dell.com">dell_za_support@dell.com</a>	
Country Code: 27	Gold Queue	011 709 7713
City Code: 11	Technical Support	011 709 7710
	Customer Care	011 709 7707
	Sales	011 709 7700
	Fax	011 706 0495
	Switchboard	011 709 7700
<b>Southeast Asian and Pacific Countries</b>	Customer Technical Support, Customer Service, and Sales (Penang, Malaysia)	604 633 4810
<b>Spain (Madrid)</b>	Website: <a href="http://support.euro.dell.com">support.euro.dell.com</a>	
International Access Code: 00	E-mail: <a href="mailto:support.euro.dell.com/es/es/emaildell/">support.euro.dell.com/es/es/emaildell/</a>	
Country Code: 34	<b>Home and Small Business</b>	
City Code: 91	Technical Support	902 100 130
	Customer Care	902 118 540
	Sales	902 118 541
	Switchboard	902 118 541
	Fax	902 118 539
	<b>Corporate</b>	
	Technical Support	902 100 130
	Customer Care	902 115 236
	Switchboard	91 722 92 00
	Fax	91 722 95 83

<b>Country (City) International Access Code Country Code City Code</b>	<b>Department Name or Service Area, Website and E-Mail Address</b>	<b>Area Codes, Local Numbers, and Toll-Free Numbers</b>
Sweden (Upplands Vasby) International Access Code: 00 Country Code: 46 City Code: 8	Website: <a href="http://support.euro.dell.com">support.euro.dell.com</a> E-mail: <a href="mailto:swe_support@dell.com">swe_support@dell.com</a> E-mail Support for Latitude and Inspiron: <a href="mailto:Swe-nbk_kats@dell.com">Swe-nbk_kats@dell.com</a> E-mail Support for OptiPlex: <a href="mailto:Swe_kats@dell.com">Swe_kats@dell.com</a> E-mail Support for Servers: <a href="mailto:Nordic_server_support@dell.com">Nordic_server_support@dell.com</a> Technical Support Relational Customer Care Home/Small Business Customer Care Employee Purchase Program (EPP) Support Technical Support Fax Sales	       08 590 05 199 08 590 05 642 08 587 70 527 20 140 14 44 08 590 05 594 08 590 05 185
Switzerland (Geneva) International Access Code: 00 Country Code: 41 City Code: 22	Website: <a href="http://support.euro.dell.com">support.euro.dell.com</a> E-mail: <a href="mailto:Tech_support_central_Europe@dell.com">Tech_support_central_Europe@dell.com</a> E-mail for French-speaking HSB and Corporate Customers: <a href="http://support.euro.dell.com/ch/fr/emaildell/">support.euro.dell.com/ch/fr/emaildell/</a> Technical Support (Home and Small Business) Technical Support (Corporate) Customer Care (Home and Small Business) Customer Care (Corporate) Fax Switchboard	    0844 811 411 0844 822 844 0848 802 202 0848 821 721 022 799 01 90 022 799 01 01
Taiwan International Access Code: 002 Country Code: 886	Technical Support (portable and desktop computers) Technical Support (servers and storage) Corporate Sales	toll-free: 00801 86 1011 toll-free: 00801 60 1256 toll-free: 00801 651 227
Thailand International Access Code: 001 Country Code: 66	Technical Support (Optiplex, Latitude, and Precision) Technical Support (PowerEdge and PowerVault) Customer Service (Penang, Malaysia) Sales	toll-free: 1800 0060 07 toll-free: 1800 0600 09 604 633 4949 toll-free: 0880 060 09

<b>Country (City) International Access Code Country Code City Code</b>	<b>Department Name or Service Area, Website and E-Mail Address</b>	<b>Area Codes, Local Numbers, and Toll-Free Numbers</b>
Trinidad/Tobago	General Support	1-800-805-8035
Turks and Caicos Islands	General Support	toll-free: 1-866-540-3355
U.K. (Bracknell)	Website: <a href="http://support.euro.dell.com">support.euro.dell.com</a>	
International Access Code: 00 Country Code: 44 City Code: 1344	Customer Care website: <a href="http://support.euro.dell.com/uk/en/ECare/Form/Home.asp">support.euro.dell.com/uk/en/ECare/Form/Home.asp</a>  E-mail: <a href="mailto:dell_direct_support@dell.com">dell_direct_support@dell.com</a>	
	Technical Support (Corporate/Preferred Accounts/PAD [1000+ employees])	0870 908 0500
	Technical Support (direct/PAD and general)	0870 908 0800
	Global Accounts Customer Care	01344 373 186
	Home and Small Business Customer Care	0870 906 0010
	Corporate Customer Care	01344 373 185
	Preferred Accounts (500–5000 employees) Customer Care	0870 906 0010
	Central Government Customer Care	01344 373 193
	Local Government & Education Customer Care	01344 373 199
	Health Customer Care	01344 373 194
	Home and Small Business Sales	0870 907 4000
	Corporate/Public Sector Sales	01344 860 456
	Home and Small Business Fax	0870 907 4006
Uruguay	General Support	toll-free: 000-413-598-2521

<b>Country (City) International Access Code Country Code City Code</b>	<b>Department Name or Service Area, Website and E-Mail Address</b>	<b>Area Codes, Local Numbers, and Toll-Free Numbers</b>
U.S.A. (Austin, Texas)	Automated Order-Status Service	toll-free: 1-800-433-9014
International Access Code: 011 Country Code: 1	AutoTech (portable and desktop computers)	toll-free: 1-800-247-9362
	<b>Consumer</b> (Home and Home Office)	
	Technical Support	toll-free: 1-800-624-9896
	Customer Service	toll-free: 1-800-624-9897
	DellNet™ Service and Support	toll-free: 1-877-Dellnet (1-877-335-5638)
	Employee Purchase Program (EPP) Customers	toll-free: 1-800-695-8133
	Financial Services website: <a href="http://www.dellfinancialservices.com">www.dellfinancialservices.com</a>	
	Financial Services (lease/loans)	toll-free: 1-877-577-3355
	Financial Services (Dell Preferred Accounts [DPA])	toll-free: 1-800-283-2210
	<b>Business</b>	
	Customer Service and Technical Support	toll-free: 1-800-822-8965
	Employee Purchase Program (EPP) Customers	toll-free: 1-800-695-8133
	Printers and Projectors Technical Support	toll-free: 1-877-459-7298
	<b>Public</b> (government, education, and healthcare)	
	Customer Service and Technical Support	toll-free: 1-800-456-3355
	Employee Purchase Program (EPP) Customers	toll-free: 1-800-234-1490
	Dell Sales	toll-free: 1-800-289-3355 or toll-free: 1-800-879-3355
	Dell Outlet Store (Dell refurbished computers)	toll-free: 1-888-798-7561
	Software and Peripherals Sales	toll-free: 1-800-671-3355
	Spare Parts Sales	toll-free: 1-800-357-3355
	Extended Service and Warranty Sales	toll-free: 1-800-247-4618
	Fax	toll-free: 1-800-727-8320
	Dell Services for the Deaf, Hard-of-Hearing, or Speech-Impaired	toll-free: 1-877-DELLTTY (1-877-335-5889)
U.S. Virgin Islands	General Support	1-877-673-3355
Venezuela	General Support	8001-3605

# U.S. Terms and Conditions of Sale

These terms and conditions ("Agreement") apply to your purchase of computer systems and/or related products and/or services and support sold in the United States ("Product") by the Dell entity named on the invoice or acknowledgement ("Dell") provided to you. By accepting delivery of the Product, you accept and are bound to the terms and conditions of this Agreement. If you do not wish to be bound by this Agreement, you must notify Dell immediately and return your purchase pursuant to Dell's Total Satisfaction Return Policy.

(See: <http://support.dell.com/ContactUs/ByPhone.aspx?c=us&l=en&s=gen> for our contact information.) If returned, Product(s) must remain in the boxes in which they were shipped. THIS AGREEMENT SHALL APPLY UNLESS (I) YOU HAVE A SEPARATE PURCHASE AGREEMENT WITH DELL, IN WHICH CASE THE SEPARATE AGREEMENT SHALL GOVERN; OR (II) OTHER DELL TERMS AND CONDITIONS APPLY TO THE TRANSACTION.

## 1. Other Documents.

This Agreement may NOT be altered, supplemented, or amended by the use of any other document(s) unless otherwise agreed to in a written agreement signed by both you and Dell. If you do not receive an invoice or acknowledgement in the mail, via e-mail, or with your Product, information about your purchase may be obtained at <https://support.dell.com/dellcare/Invoice.aspx> or by contacting your sales representative.

## 2. Payment Terms; Orders; Quotes; Interest.

Payment terms are within Dell's sole discretion, and, unless otherwise agreed to by Dell, payment must be made at the time of purchase. Payment for Product may be made by credit card, wire transfer, or some other prearranged payment method. Dell may invoice parts of an order separately. Your order is subject to cancellation by Dell, at Dell's sole discretion. Unless you and Dell have agreed to a different discount, Dell's standard pricing policy for Dell-branded systems, which include both hardware and services in one discounted price, allocates the discount off list price applicable to the service portion of the system to be equal to the overall calculated percentage discount off list price on the entire system. Dell is not responsible for pricing, typographical, or other errors, in any offer by Dell and reserves the right to cancel any orders resulting from such errors.

## 3. Shipping Charges; Taxes; Title; Risk of Loss.

Shipping and handling are additional unless otherwise expressly indicated at the time of sale. Loss or damage that occurs during shipping by a carrier selected by Dell is Dell's responsibility. Loss or damage that occurs during shipping by a carrier selected by you is your responsibility. You must notify Dell within 30 days of the date of your invoice or acknowledgement if you believe any part of your purchase is missing, wrong or damaged. Unless you provide Dell with a valid and correct tax exemption certificate applicable to your purchase of Product and the Product ship-to location, you are responsible for sales and other taxes associated with the order. Shipping dates are estimates only. Title to software will remain with the applicable licensor(s).

## 4. Warranties.

THE LIMITED WARRANTIES APPLICABLE TO DELL-BRANDED HARDWARE PRODUCT CAN BE FOUND AT <http://www.dell.com/policy/legal/warranty.htm> OR IN THE DOCUMENTATION DELL PROVIDES WITH THE PRODUCT. DELL MAKES NO WARRANTIES FOR SERVICE, SOFTWARE, OR NON-DELL BRANDED PRODUCT. SUCH PRODUCT IS PROVIDED BY DELL "AS IS." WARRANTY AND SERVICE FOR NON-DELL BRANDED PRODUCT, IF ANY, IS PROVIDED BY THE ORIGINAL MANUFACTURER, NOT BY DELL. DELL MAKES NO EXPRESS WARRANTIES EXCEPT THOSE STATED IN DELL'S APPLICABLE WARRANTY STATEMENT IN EFFECT ON THE DATE OF THE INVOICE, PACKING SLIP OR ACKNOWLEDGEMENT. WARRANTIES AND SERVICE WILL BE EFFECTIVE, AND DELL WILL BE OBLIGATED TO HONOR ANY SUCH WARRANTIES AND SERVICES, ONLY UPON DELL'S RECEIPT OF PAYMENT IN FULL FOR THE ITEM TO BE WARRANTED OR SERVICED.

## 5. Software.

All software is provided subject to the license agreement that is part of the software package and you agree that you will be bound by such license agreement.

## 6. Return Policies; Exchanges.

New and refurbished Product that you purchase directly from Dell (and not a third party) you may return or exchange only in accordance with Dell's return policy in effect on the date of the invoice or acknowledgement. Any returns or exchanges will be made in accordance with Dell's exchange policies in effect on the date of the return or exchange. You must contact us directly before you attempt to return Product to obtain a Return Material Authorization Number for you to include with your return. You must return Product to us in their original or equivalent packaging. You are responsible for risk of loss, shipping and handling fees for returning or exchanging Product. Additional fees may apply. Dell's return policy for Dell-branded Product can be found at:

<http://www.dell.com/policy/legal/warranty.htm>. Non-Dell branded software and peripheral return policies can be found at: [http://rcommerce.us.dell.com/rcomm/include/dw\\_policies.htm](http://rcommerce.us.dell.com/rcomm/include/dw_policies.htm).

Refurbished Product return policies can be found at:

[http://www.dell.com/us/en/dfh/topics/segtopic\\_nav\\_info\\_002\\_info.htm](http://www.dell.com/us/en/dfh/topics/segtopic_nav_info_002_info.htm). If you fail to follow the return or exchange instructions and policies provided by Dell, Dell is not responsible whatsoever for Product that is lost, damaged, modified or otherwise processed for disposal or resale. If you are returning all components in an order, you will be credited the full amount paid for the order. At Dell's discretion, credit for partial returns may be less than invoice or individual component prices due to bundled or promotional pricing.

## 7. Changed or Discontinued Product.

Dell's policy is one of ongoing update and revision. Dell may revise and discontinue Product at any time without notice to you and this may affect information saved in your online "cart." Dell will ship Product that has the functionality and performance of the Product ordered, but changes between what is shipped and what is described in a specification sheet or catalog are possible. Parts used in repairing or servicing Product may be new, equivalent-to-new, or reconditioned.

## 8. Service and Support.

Service offerings may vary from Product to Product. If you purchase optional services and support from Dell, Dell and/or your third-party service provider will provide such service and support to you in the United States in accordance with the terms and conditions located at

[http://www.dell.com/us/en/gen/services/service\\_service\\_contracts.htm](http://www.dell.com/us/en/gen/services/service_service_contracts.htm) or as mailed to you. You may contact Dell for more information, see <http://www1.us.dell.com/content/topics/segtopic.aspx/contact/contact?c=us&l=en&s=gen> for contact information. Dell and/or the third-party service provider may at their discretion, revise their general and optional service and support programs and the terms and conditions that govern them without prior notice to you. Dell has no obligation to provide service or support until Dell has received full payment for the Product or service/support contract you purchased. Dell is not obligated to provide service or support you purchase through a third party and not Dell.

## 9. Limitation of Liability.

DELL DOES NOT ACCEPT LIABILITY BEYOND THE REMEDIES SET FORTH HEREIN, INCLUDING BUT NOT LIMITED TO ANY LIABILITY FOR PRODUCT NOT BEING AVAILABLE FOR USE, LOST PROFITS, LOSS OF BUSINESS OR FOR LOST OR CORRUPTED DATA OR SOFTWARE, OR THE PROVISION OF SERVICES AND SUPPORT. EXCEPT AS EXPRESSLY PROVIDED HEREIN, DELL WILL NOT BE LIABLE FOR ANY CONSEQUENTIAL, SPECIAL, INDIRECT, OR PUNITIVE DAMAGES, EVEN IF ADVISED OF THE POSSIBILITY OF SUCH DAMAGES, OR FOR ANY CLAIM BY ANY THIRD PARTY. YOU AGREE THAT FOR ANY LIABILITY RELATED TO THE PURCHASE OF PRODUCT, DELL IS NOT LIABLE OR RESPONSIBLE FOR ANY AMOUNT OF DAMAGES ABOVE THE AMOUNT INVOICED FOR THE APPLICABLE PRODUCT. NOTWITHSTANDING ANYTHING IN THIS AGREEMENT TO THE CONTRARY, THE REMEDIES SET FORTH IN THIS AGREEMENT SHALL APPLY EVEN IF SUCH REMEDIES FAIL THEIR ESSENTIAL PURPOSE. DELL IS NOT LIABLE TO YOU FOR WARRANTIES, SUPPORT, OR SERVICE MADE BY OR PURCHASED FROM A THIRD PARTY AND NOT DIRECTLY FROM DELL. DELL IS NOT RESPONSIBLE FOR REPRESENTATIONS OR OMISSIONS MADE BY A THIRD PARTY.



#### **10. Applicable Law; Not For Resale or Export.**

You agree to comply with all applicable laws and regulations of the various states and of the United States. You agree and represent that you are buying only for your own internal use only, and not for resale or export. Dell has separate terms and conditions governing resale of Product by third parties and transactions outside the United States. Terms and conditions for resale are located at: <http://www.dell.com/policy/legal/termsofsale.htm>.

#### **11. Governing Law.**

**THIS AGREEMENT AND ANY SALES THERE UNDER SHALL BE GOVERNED BY THE LAWS OF THE STATE OF TEXAS, WITHOUT REGARD TO CONFLICTS OF LAWS RULES.**

#### **12. Headings.**

The section headings used herein are for convenience of reference only and do not form a part of these terms and conditions, and no construction or inference shall be derived there from.

#### **13. Binding Arbitration.**

ANY CLAIM, DISPUTE, OR CONTROVERSY (WHETHER IN CONTRACT, TORT, OR OTHERWISE, WHETHER PREEXISTING, PRESENT OR FUTURE, AND INCLUDING STATUTORY, COMMON LAW, INTENTIONAL TORT AND EQUITABLE CLAIMS) BETWEEN CUSTOMER AND DELL, its agents, employees, principals, successors, assigns, affiliates (collectively for purposes of this paragraph, "Dell") arising from or relating to this Agreement, its interpretation, or the breach, termination or validity thereof, the relationships which result from this Agreement (including, to the full extent permitted by applicable law, relationships with third parties who are not signatories to this Agreement), Dell's advertising, or any related purchase SHALL BE RESOLVED EXCLUSIVELY AND FINALLY BY BINDING ARBITRATION ADMINISTERED BY THE NATIONAL ARBITRATION FORUM (NAF) under its Code of Procedure then in effect (available via the Internet at <http://www.arb-forum.com>, or via telephone at 1-800-474-2371). The arbitration will be limited solely to the dispute or controversy between customer and Dell. NEITHER CUSTOMER NOR DELL SHALL BE ENTITLED TO JOIN OR CONSOLIDATE CLAIMS BY OR AGAINST OTHER CUSTOMERS, OR ARBITRATE ANY CLAIM AS A REPRESENTATIVE OR CLASS ACTION OR IN A PRIVATE ATTORNEY GENERAL CAPACITY. This transaction involves interstate commerce, and this provision shall be governed by the Federal Arbitration Act 9 U.S.C. sec. 1-16 (FAA). Any award of the arbitrator(s) shall be final and binding on each of the parties, and may be entered as a judgment in any court of competent jurisdiction. Dell will be responsible for paying any arbitration filing fees and fees required to obtain a hearing to the extent such fees exceed the amount of the filing fee for initiating a claim in the court of general jurisdiction in the state in which you reside. Each party shall pay for its own costs and attorneys' fees, if any. However, if any party prevails on a statutory claim that affords the prevailing party attorneys' fees, or if there is a written agreement providing for fees, the Arbitrator may award reasonable fees to the prevailing party, under the standards for fee shifting provided by law. Information may be obtained and claims may be filed with the NAF at P.O. Box 50191, Minneapolis, MN 55405. (REV 4/04)

## **Limited Warranties and Return Policy**

Dell-branded hardware products purchased in the U.S. or Canada come with either a 90-day, 1-year, 2-year, 3-year, or 4-year limited warranty depending on the product purchased. To determine which warranty came with your hardware product(s), see your packing slip or invoice. The following sections describe the limited warranties for the U.S., the limited warranties for Canada, the manufacturer guarantee for Latin America and the Caribbean, and the Intel<sup>®</sup> Pentium<sup>®</sup> and Celeron<sup>®</sup> warranty for the U.S. and Canada.

### **Limited Warranty for Dell-Branded Hardware Products (U.S. Only)**

#### **What is covered by this limited warranty?**

This limited warranty covers defects in materials and workmanship in your—our end-user customer's—Dell-branded hardware products, including Dell-branded peripheral products.

## What is not covered by this limited warranty?

This limited warranty does not cover:

- Software, including the operating system and software added to the Dell-branded hardware products through our factory-integration system, third-party software, or the reloading of software
- Non-Dell-branded and Solution Provider Direct products and accessories
- Problems that result from:
  - External causes such as accident, abuse, misuse, or problems with electrical power
  - Servicing not authorized by Dell
  - Usage that is not in accordance with product instructions
  - Failure to follow the product instructions or failure to perform preventive maintenance
  - Problems caused by using accessories, parts, or components not supplied by Dell
- Products with missing or altered Service Tags or serial numbers
- Products for which Dell has not received payment

THIS WARRANTY GIVES YOU SPECIFIC LEGAL RIGHTS, AND YOU MAY ALSO HAVE OTHER RIGHTS WHICH VARY FROM STATE TO STATE (OR JURISDICTION TO JURISDICTION). DELL'S RESPONSIBILITY FOR MALFUNCTIONS AND DEFECTS IN HARDWARE IS LIMITED TO REPAIR AND REPLACEMENT AS SET FORTH IN THIS WARRANTY STATEMENT. ALL EXPRESS AND IMPLIED WARRANTIES FOR THE PRODUCT, INCLUDING BUT NOT LIMITED TO ANY IMPLIED WARRANTIES AND CONDITIONS OF MERCHANTABILITY AND FITNESS FOR A PARTICULAR PURPOSE, ARE LIMITED IN TIME TO THE TERM OF THE LIMITED WARRANTY PERIOD REFLECTED ON YOUR PACKING SLIP OR INVOICE. NO WARRANTIES, WHETHER EXPRESS OR IMPLIED, WILL APPLY AFTER THE LIMITED WARRANTY PERIOD HAS EXPIRED. SOME STATES DO NOT ALLOW LIMITATIONS ON HOW LONG AN IMPLIED WARRANTY LASTS, SO THIS LIMITATION MAY NOT APPLY TO YOU.

WE DO NOT ACCEPT LIABILITY BEYOND THE REMEDIES PROVIDED FOR IN THIS LIMITED WARRANTY OR FOR CONSEQUENTIAL OR INCIDENTAL DAMAGES, INCLUDING, WITHOUT LIMITATION, ANY LIABILITY FOR THIRD-PARTY CLAIMS AGAINST YOU FOR DAMAGES, FOR PRODUCTS NOT BEING AVAILABLE FOR USE, OR FOR LOST DATA OR LOST SOFTWARE. OUR LIABILITY WILL BE NO MORE THAN THE AMOUNT YOU PAID FOR THE PRODUCT THAT IS THE SUBJECT OF A CLAIM. THIS IS THE MAXIMUM AMOUNT FOR WHICH WE ARE RESPONSIBLE.

SOME STATES DO NOT ALLOW THE EXCLUSION OR LIMITATION OF INCIDENTAL OR CONSEQUENTIAL DAMAGES, SO THE ABOVE LIMITATION OR EXCLUSION MAY NOT APPLY TO YOU.

## How long does this limited warranty last?

This limited warranty lasts for the time period indicated on your packing slip or invoice, except for the following Dell-branded hardware:

- Portable computer batteries carry a 1-year limited warranty.
- Projector lamps carry a 90-day limited warranty.
- Memory carries a lifetime limited warranty.
- Monitors carry the longer of either a 3-year limited warranty or the remainder of the warranty for the Dell computer to which the monitor will be connected.
- PDAs, MP3 players, earphones, remote inline controls, and AC adapters carry a 1-year limited warranty.

- Other add-on hardware carries the longer of either a 1-year limited warranty for new parts and a 90-day limited warranty for reconditioned parts or, for both new and reconditioned parts, the remainder of the warranty for the Dell computer on which such parts are installed.

The limited warranty on all Dell-branded products begins on the date of the packing slip or invoice. The warranty period is not extended if we repair or replace a warranted product or any parts. Dell may change the availability of limited warranties, at its discretion, but any changes will not be retroactive.

### What do I do if I need warranty service?

Before the warranty expires, please call us at the relevant number listed in the following table. Please also have your Dell Service Tag or order number available.

<b>Web Support</b>	<a href="http://support.dell.com/ContactUs/ContactUsHome.aspx?c=us&amp;l=en&amp;s=gen">support.dell.com/ContactUs/ContactUsHome.aspx?c=us&amp;l=en&amp;s=gen</a>
<b>Individual Home Consumers:</b>	<b>U.S. Only</b>
Technical Support	1-800-624-9896
Customer Service	1-800-624-9897
<b>Individual Home Consumers who purchased through an Employee Purchase Program:</b>	
Technical Support and Customer Service	1-800-822-8965
<b>Home and Small Business Commercial Customers:</b>	
Technical Support and Customer Service	1-800-456-3355
<b>Medium, Large, or Global Commercial Customers, Healthcare Customers, and Value-Added Resellers (VARs):</b>	
Technical Support and Customer Service	1-877-459-7298
<b>Government and Education Customers:</b>	
Technical Support and Customer Service	1-877-459-7298
<b>Dell-Branded Memory</b>	1-888-363-5150

### What will Dell do?

**During the 90 days of the 90-day limited warranty and the first year of all other limited warranties:** During the 90 days of the 90-day limited warranty and the first year of all other limited warranties, we will repair any Dell-branded hardware products returned to us that prove to be defective in materials or workmanship. If we are not able to repair the product, we will replace it with a comparable product that is new or refurbished.

When you contact us, we will issue a Return Material Authorization Number for you to include with your return. You must return the products to us in their original or equivalent packaging, prepay shipping charges, and insure the shipment or accept the risk if the product is lost or damaged in shipment. We will return the repaired or replacement products to you. We will pay to ship the repaired or replaced products to you if you use an address in the United States (excluding Puerto Rico and U.S. possessions and territories). Otherwise, we will ship the product to you freight collect.

If we determine that the product is not covered under this warranty, we will notify you and inform you of service alternatives that are available to you on a fee basis.

 **NOTE:** Before you ship the product(s) to us, make sure to back up the data on the hard drive(s) and any other storage device(s) in the product(s). Remove any confidential, proprietary, or personal information and removable media such as floppy disks, CDs, or PC Cards. We are not responsible for any of your confidential, proprietary, or personal information; lost or corrupted data; or damaged or lost removable media.

**During the remaining years:** For the remaining period of the limited warranty, we will replace any defective part with new or refurbished parts, if we agree that it needs to be replaced. When you contact us, we will require a valid credit card number at the time you request a replacement part, but we will not charge you for the replacement part as long as you return the original part to us within 30 days after we ship the replacement part to you. If we do not receive the original part within 30 days, we will charge to your credit card the then-current standard price for that part.

We will pay to ship the part to you if you use an address in the United States (excluding Puerto Rico and U.S. possessions and territories). Otherwise, we will ship the part freight collect. We will also include a prepaid shipping container with each replacement part for your use in returning the replaced part to us.

 **NOTE:** Before you replace parts, make sure to back up the data on the hard drive(s) and any other storage device(s) in the product(s). We are not responsible for lost or corrupted data.

### **What if I purchased a service contract?**

If your service contract is with Dell, service will be provided to you under the terms of the service agreement. Please refer to that contract for details on how to obtain service.

If you purchased through us a service contract with one of our third-party service providers, please refer to that contract for details on how to obtain service.

### **How will you fix my product?**

We use new and refurbished parts made by various manufacturers in performing warranty repairs and in building replacement parts and systems. Refurbished parts and systems are parts or systems that have been returned to Dell, some of which were never used by a customer. All parts and systems are inspected and tested for quality. Replacement parts and systems are covered for the remaining period of the limited warranty for the product you bought. Dell owns all parts removed from repaired products.

### **May I transfer the limited warranty?**

Limited warranties on systems may be transferred if the current owner transfers ownership of the system and records the transfer with us. The limited warranty on Dell-branded memory may not be transferred. You may record your transfer by going to Dell's website:

- If you are an Individual Home Consumer, go to [www.dell.com/us/en/dhs/topics/sbtopic\\_015\\_ccare.htm](http://www.dell.com/us/en/dhs/topics/sbtopic_015_ccare.htm)
- If you are a Home Office, Small, Medium, Large, or Global Commercial Customer, go to [www.dell.com/us/en/biz/topics/sbtopic\\_ccare\\_nav\\_015\\_ccare.htm](http://www.dell.com/us/en/biz/topics/sbtopic_ccare_nav_015_ccare.htm)
- If you are a Government, Education, or Healthcare Customer, or an Individual Home Consumer who purchased through an Employee Purchase Program, go to [www.dell.com/us/en/pub/topics/sbtopic\\_015\\_ccare.htm](http://www.dell.com/us/en/pub/topics/sbtopic_015_ccare.htm)

If you do not have Internet access, call your customer care representative or call 1-800-624-9897.

All requests to transfer ownership are at Dell's sole discretion. All such transfers will be subject to the terms and conditions of the original service or limited warranty agreement and Dell's terms and conditions of sale located at [www.dell.com](http://www.dell.com). Dell cannot guarantee the authenticity of the products, limited warranties, service or support, or the accuracy of the listings of products you purchase from a third party.

## Total Satisfaction Return Policy (U.S. Only)

We value our relationship with you and want to make sure that you are satisfied with your purchases. That is why we offer a Total Satisfaction return policy for most products that you, the end-user customer, purchase directly from Dell. Under this policy, you may return to Dell products that you purchased directly from Dell for a credit or a refund of the purchase price paid, less shipping and handling and applicable return fees as follows:

**New Hardware Products and Accessories** — Unless you have a separate agreement with Dell, all hardware, accessories, peripherals, parts, and unopened software still in its sealed package, excluding the products listed below, may be returned within twenty-one (21) days from the date on the packing slip or invoice. New Dell PowerEdge™, PowerConnect™, and PowerVault™ products may be returned within thirty (30) days from the date on the packing slip or invoice except that new PowerEdge SC servers and n series products purchased from the Small and Medium Business Sales Division may only be returned within fourteen (14) days from the date on the packing slip or invoice. To return applications software or an operating system that has been installed by Dell, you must return the entire computer. A different return policy applies to nondefective products purchased through Dell's Software and Peripherals division by customers of our Small and Medium Business divisions. Those products may be returned within twenty-one (21) days from the date on the packing slip or invoice, but a fifteen percent (15%) return fee will be deducted from any refund or credit. The Total Satisfaction Return Policy and Software and Peripherals division return policy are not available for Dell | EMC storage products, EMC-branded products, Unisys-branded products, PowerVault™, 160T tape libraries, enterprise software, non-Dell branded enterprise products, software and/or software licenses purchased under any type of volume purchase agreement or any non-Dell customized hardware and/or software product(s).

**Reconditioned or Refurbished Dell-Branded Hardware Products and Parts** — All reconditioned or refurbished PowerEdge, PowerConnect, and PowerVault products may be returned within thirty (30) days from the date on the packing slip or invoice. All other reconditioned or refurbished Dell-branded hardware products and parts may be returned within fourteen (14) days of the date on the packing slip or invoice.

**How to Return** — To return products, e-mail or call Dell customer service to receive a Credit Return Authorization Number within the return policy period applicable to the product you want to return. You must obtain a Credit Return Authorization Number in order to return the product. See "Contacting Dell" or "Getting Help" in your customer documentation (or go to [www.dell.com/us/en/gen/contact.htm](http://www.dell.com/us/en/gen/contact.htm)) to find the appropriate contact information for obtaining customer assistance.

You must ship the products to Dell within five (5) days of the date that Dell issues the Credit Return Authorization Number. You must also return the products to Dell in their original packaging, in as-new condition along with any media, documentation, and all other items that were included in the original shipment, prepay shipping charges, and insure the shipment or accept the risk of loss or damage during shipment.



**NOTE:** Before you ship the product(s) to us, make sure to back up the data on the hard drive(s) and any other storage device(s) in the product(s). Remove any confidential, proprietary, or personal information and removable media such as floppy disks, CDs, or PC Cards. We are not responsible for any of your confidential, proprietary, or personal information; lost or corrupted data; or damaged or lost removable media.

## Limited Warranty Terms for Dell-Branded Hardware Products (Canada Only)

### What is covered by this limited warranty?

This limited warranty covers defects in materials and workmanship in your—our end-user customer's—Dell-branded hardware products, including Dell-branded peripheral products.

## What is not covered by this limited warranty?

This limited warranty does not cover:

- Software, including the operating system and software added to the Dell-branded hardware products through our factory-integration system, or the reloading of the software
- Non-Dell branded and Solution Provider Direct products and accessories
- Problems that result from:
  - External causes such as accident, abuse, misuse, or problems with electrical power
  - Servicing not authorized by Dell
  - Usage that is not in accordance with product instructions
  - Failure to follow the product instructions or failure to perform preventive maintenance
  - Problems caused by using accessories, parts, or components not supplied by Dell
- Products with missing or altered Service Tags or serial numbers
- Products for which Dell has not received payment

THIS WARRANTY GIVES YOU SPECIFIC LEGAL RIGHTS, AND YOU MAY ALSO HAVE OTHER RIGHTS WHICH VARY FROM PROVINCE TO PROVINCE. DELL'S RESPONSIBILITY FOR MALFUNCTIONS AND DEFECTS IN PRODUCT IS LIMITED TO REPAIR AND REPLACEMENT AS SET FORTH IN THIS WARRANTY STATEMENT, FOR THE TERM OF THE WARRANTY PERIOD REFLECTED ON YOUR PACKING SLIP OR INVOICE. EXCEPT FOR THE EXPRESS WARRANTIES CONTAINED IN THIS WARRANTY STATEMENT, DELL DISCLAIMS ALL OTHER WARRANTIES AND CONDITIONS, EXPRESS OR IMPLIED, INCLUDING WITHOUT LIMITATION IMPLIED WARRANTIES AND CONDITIONS OF MERCHANTABILITY AND FITNESS FOR A PARTICULAR PURPOSE, STATUTORY OR OTHERWISE. SOME PROVINCES DO NOT ALLOW THE EXCLUSION OF CERTAIN IMPLIED WARRANTIES OR CONDITIONS, OR LIMITATIONS ON HOW LONG AN IMPLIED WARRANTY OR CONDITION LASTS. THEREFORE, THE FOREGOING EXCLUSIONS AND LIMITATIONS MAY NOT APPLY TO YOU.

WE DO NOT ACCEPT LIABILITY BEYOND THE REMEDIES PROVIDED FOR IN THIS WARRANTY STATEMENT OR FOR SPECIAL, INDIRECT, CONSEQUENTIAL, OR INCIDENTAL DAMAGES, INCLUDING, WITHOUT LIMITATION, ANY LIABILITY FOR THIRD-PARTY CLAIMS AGAINST YOU FOR DAMAGES, FOR PRODUCTS NOT BEING AVAILABLE FOR USE, OR FOR LOST DATA OR LOST SOFTWARE. OUR LIABILITY WILL BE NO MORE THAN THE AMOUNT YOU PAID FOR THE PRODUCT THAT IS THE SUBJECT OF A CLAIM. THIS IS THE MAXIMUM AMOUNT FOR WHICH WE ARE RESPONSIBLE.

SOME PROVINCES DO NOT ALLOW THE EXCLUSION OR LIMITATION OF SPECIAL, INDIRECT, INCIDENTAL, OR CONSEQUENTIAL DAMAGES, SO THE ABOVE LIMITATION OR EXCLUSION MAY NOT APPLY TO YOU.

## How long does this limited warranty last?

This limited warranty lasts for the time period indicated on your packing slip or invoice, except that the limited warranty on Dell-branded batteries lasts only 1 year and the limited warranty on the lamps for Dell-branded projectors lasts only 90 days. The limited warranty begins on the date of the packing slip or invoice. The warranty period is not extended if we repair or replace a warranted product or any parts. Dell may change the terms and availability of limited warranties, at its discretion, but any changes will not be retroactive (that is, the warranty terms in place at the time of purchase will apply to your purchase).

## What do I do if I need warranty service?

Before the warranty expires, please call us at the relevant number listed in the following table. Please also have your Dell Service Tag or order number available.

<b>Web Support</b>	support.dell.com/ContactUs/ContactUsHome.aspx?c=us&l=en&s=gen
<b>Individual Home Consumers; Home Office and Small Business Customers:</b>	<b>Canada Only</b>
Technical Support and Customer Service	1-800-847-4096
<b>Medium, Large, and Global Commercial Customers; Government, Education, and Healthcare Customers; and Value-Added Resellers (VARs):</b>	
Technical Support	1-800-387-5757
Customer Service	1-800-326-9463
<b>Government or Education Customers, or Individual Home Consumers who purchased through an Employee Purchase Program:</b>	
Technical Support	1-800-387-5757
Customer Service	1-800-326-9463 (Extension 8221 for Individual Consumers)
<b>Dell-Branded Memory</b>	1-888-363-5150

## What will Dell do?

**During the 90 days of the 90-day limited warranty and the first year of all other limited warranties:** During the 90 days of the 90-day limited warranty and the first year of all other limited warranties, we will repair any Dell-branded hardware products returned to us that prove to be defective in materials or workmanship. If we are not able to repair the product, we will replace it with a comparable product that is new or refurbished.

When you contact us, we will issue a Return Material Authorization Number for you to include with your return. You must return the products to us in their original or equivalent packaging, prepay shipping charges, and insure the shipment or accept the risk if the product is lost or damaged in shipment. We will return the repaired or replacement products to you. We will pay to ship the repaired or replaced products to you if you use an address in Canada. Otherwise, we will ship the product to you freight collect.

If we determine that the problem is not covered under this warranty, we will notify you and inform you of service alternatives that are available to you on a fee basis.



**NOTE:** Before you ship the product(s) to us, make sure to back up the data on the hard drive(s) and any other storage device(s) in the product(s). Remove any confidential, proprietary, or personal information and removable media such as floppy disks, CDs, or PC Cards. We are not responsible for any of your confidential, proprietary, or personal information; lost or corrupted data; or damaged or lost removable media.

**During the remaining years following the first year of all limited warranties:** We will replace any defective part with new or refurbished parts, if we agree that it needs to be replaced. When you contact us, we will require a valid credit card number at the time you request a replacement part, but we will not charge you for the replacement part as long as you return the original part to us within 30 days after we ship the replacement part to you. If we do not receive the original part within 30 days, we will charge to your credit card the then-current standard price for that part.

We will pay to ship the part to you if you use an address in Canada. Otherwise, we will ship the part freight collect. We will also include a prepaid shipping container with each replacement part for your use in returning the replaced part to us.

 **NOTE:** Before you replace parts, make sure to back up the data on the hard drive(s) and any other storage device(s) in the product(s). We are not responsible for lost or corrupted data.

### **What if I purchased a service contract?**

If your service contract is with Dell, service will be provided to you under the terms of the service contract. Please refer to that contract for details on how to obtain service. Dell's service contracts can be found online at [www.dell.ca](http://www.dell.ca) or by calling Customer Care at 1-800-847-4096. If you purchased through us a service contract with one of our third-party service providers, please refer to that contract (mailed to you with your packing slip or invoice) for details on how to obtain service.

### **How will you fix my product?**

We use new and refurbished parts made by various manufacturers in performing warranty repairs and in building replacement parts and systems. Refurbished parts and systems are parts or systems that have been returned to Dell, some of which were never used by a customer. All parts and systems are inspected and tested for quality. Replacement parts and systems are covered for the remaining period of the limited warranty for the product you bought. Dell owns all parts removed from repaired products.

### **May I transfer the limited warranty?**

Limited warranties on systems may be transferred if the current owner transfers ownership of the system and records the transfer with us. The limited warranty on Dell-branded memory may not be transferred. You may record your transfer by going to Dell's website.

- For Canada-purchased computers (in-country transfers) and to transfer from one customer to another, go to [www.dell.ca/ca/en/gen/topics/segtopic\\_ccare\\_nav\\_013\\_ccare.htm](http://www.dell.ca/ca/en/gen/topics/segtopic_ccare_nav_013_ccare.htm)
- For out-of-country transfers (outside of the original country of purchase), go to [www.dell.com/us/en/biz/topics/sbtopic\\_ccare\\_nav\\_016\\_ccare.htm](http://www.dell.com/us/en/biz/topics/sbtopic_ccare_nav_016_ccare.htm)

If you do not have Internet access, call Dell at 1-800-847-4096 (Home Consumer customers) or 1-800-326-9463 (Corporate Commercial or Government customers).

All requests to transfer ownership are at Dell's sole discretion. All such transfers will be subject to the terms and conditions of the original service or limited warranty agreement and Dell's terms and conditions of sale located at [www.dell.com](http://www.dell.com). Dell cannot guarantee the authenticity of the products, limited warranties, service or support, or the accuracy of the listings of products you purchase from a third party.

### **Total Satisfaction Return Policy (Canada Only)**

If you are an end-user customer who bought new products directly from Dell, you may return them to Dell up to 30 days after you receive them for a refund or credit of the product purchase price. If you are an end-user customer who bought reconditioned or refurbished products from Dell, you may return them to Dell within 14 days after the date on the packing slip or invoice for a refund or credit of the product purchase price. In either case, the refund or credit will not include any shipping and handling charges shown on your packing slip or invoice and will be subject to a fifteen percent (15%) restocking fee, unless otherwise prohibited by law. If you are an organization that bought the products under a written agreement with Dell, the agreement may contain different terms for the return of products than specified by this policy.



To return products, you must call Dell Customer Service at 1-800-847-4096 to receive a Credit Return Authorization Number. To expedite the process of your refund or credit, Dell expects you to return the products to Dell in their original packaging within 5 days of the date that Dell issues the Credit Return Authorization Number. You must also prepay shipping charges and insure the shipment or accept the risk of loss or damage during shipment. You may return software for a refund or credit only if the sealed package containing the diskette(s) or CD(s) is unopened. Returned products must be in as-new condition, and all of the manuals, diskette(s), CD(s), power cables, and other items included with a product must be returned with it. For customers who want to return, for refund or credit only, either application or operating system software that has been installed by Dell, the whole system must be returned, along with any media and documentation that may have been included in the original shipment.

The "Total Satisfaction" Return Policy does not apply to Dell | EMC storage products. It also does not apply to products purchased through Dell's Software and Peripherals division. For those products, please instead refer to Dell's Software and Peripheral's then-current return policy (see the following section, "Dell Software and Peripherals [Canada Only]").

## **Dell Software and Peripherals (Canada Only)**

### **Third-Party Software and Peripherals Products**

Similar to other resellers of software and peripherals, Dell does not warrant third-party products. Third-party software and peripheral products are covered by the warranties provided by the original manufacturer or publisher only. Third-party manufacturer warranties vary from product to product. Consult your product documentation for specific warranty information. More information may also be available from the manufacturer or publisher.

While Dell offers a wide selection of software and peripheral products, we do not specifically test or guarantee that all of the products we offer work with any or all of the various models of Dell computers, nor do we test or guarantee all of the products we sell on the hundreds of different brands of computers available today. If you have questions about compatibility, we recommend and encourage you to contact the third-party software and peripheral product manufacturer or publisher directly.

### **Dell-Branded Peripheral Products**

Dell does provide a limited warranty for new Dell-branded peripheral products (products for which Dell is listed as the manufacturer) such as monitors, batteries, memory, docking stations, and projectors. To determine which limited warranty applies to the product you purchased, see the Dell packing slip or invoice and/or the product documentation that accompanied your product. Descriptions of Dell's limited warranties are described in preceding sections.

## **1-Year End-User Manufacturer Guarantee (Latin America and the Caribbean Only)**

### **Guarantee**

Dell Inc. ("Dell") warrants to the end user in accordance with the following provisions that its branded hardware products, purchased by the end user from a Dell company or an authorized Dell distributor in Latin America or the Caribbean, will be free from defects in materials, workmanship, and design affecting normal use, for a period of 1 year from the original purchase date. Products for which proper claims are made will, at Dell's option, be repaired or replaced at Dell's expense. Dell owns all parts removed from repaired products. Dell uses new and reconditioned parts made by various manufacturers in performing repairs and building replacement products.

### **Exclusions**

This Guarantee does not apply to defects resulting from: improper or inadequate installation, use, or maintenance; actions or modifications by unauthorized third parties or the end user; accidental or willful damage; or normal wear and tear.

## **Making a Claim**

Claims must be made in Latin America or the Caribbean by contacting the Dell point of sale within the guarantee period. The end user must always supply proof of purchase, indicating name and address of the seller, date of purchase, model and serial number, name and address of the customer, and details of symptoms and configuration at the time of malfunction, including peripherals and software used. Otherwise, Dell may refuse the guarantee claim. Upon diagnosis of a warranted defect, Dell will make arrangements and pay for ground freight and insurance to and from Dell's repair/replacement center. The end user must ensure that the defective product is available for collection properly packed in original or equally protective packaging together with the details listed above and the return number provided to the end user by Dell.

## **Limitation and Statutory Rights**

Dell makes no other warranty, guarantee or like statement other than as explicitly stated above, and this Guarantee is given in place of all other guarantees whatsoever, to the fullest extent permitted by law. In the absence of applicable legislation, this Guarantee will be the end user's sole and exclusive remedy against Dell or any of its affiliates, and neither Dell nor any of its affiliates shall be liable for loss of profit or contracts, or any other indirect or consequential loss arising from negligence, breach of contract, or howsoever.

**This Guarantee does not impair or affect mandatory statutory rights of the end user against and/or any rights resulting from other contracts concluded by the end user with Dell and/or any other seller.**

### **Dell World Trade LP**

One Dell Way, Round Rock, TX 78682, USA

### **Dell Computadores do Brasil Ltda (CNPJ No. 72.381.189/0001-10)**

Avenida Industrial Belgraf, 400  
92990-000 - Eldorado do Sul – RS - Brasil

### **Dell Computer de Chile Ltda**

Coyancura 2283, Piso 3- Of.302,  
Providencia, Santiago - Chile

### **Dell Computer de Colombia Corporation**

Carrera 7 #115-33 Oficina 603  
Bogota, Colombia

### **Dell Computer de Mexico SA de CV**

Paseo de la Reforma 2620 - 11° Piso  
Col. Lomas Altas  
11950 México, D.F.

# **Dell Inc.**

## **Ink and Toner Cartridges Limited Warranties**

The following sections describe the limited warranty for ink and Toner Cartridges for the U.S., Canada, and Latin America. Refer to the appropriate limited warranty accordingly.

### **Ink and Toner Cartridges Limited Warranty (U.S. and Canada Only)**

Dell Inc. warrants to the original purchaser of genuine Dell-branded Toner Cartridges that they will be free from defects in material and workmanship for the life of the cartridge and that for genuine Dell-branded ink cartridges they will be free from defects in material and workmanship for two years beginning on the date of invoice. If this product proves defective in either material or workmanship, it will be replaced without charge during the limited warranty period if returned to Dell. You must first call our toll-free number to get your return authorization. In the U.S., call 1-877-459-7298; in Canada, call 1-800-847-4096. If we are not able to replace the product because it has been discontinued or is not available, we will either replace it with a comparable product or reimburse you for the cartridge purchase cost, at Dell's sole option. This limited warranty does not apply to ink or Toner Cartridges that have been refilled or improperly stored or due to problems resulting from misuse, abuse, accident, neglect, mishandling, incorrect environments, or wear from ordinary use.

THIS WARRANTY GIVES YOU SPECIFIC LEGAL RIGHTS, AND YOU MAY ALSO HAVE OTHER RIGHTS WHICH VARY FROM STATE TO STATE (OR JURISDICTION TO JURISDICTION). DELL'S RESPONSIBILITY FOR MALFUNCTIONS AND DEFECTS IN HARDWARE IS LIMITED TO REPLACEMENT AS SET FORTH IN THIS WARRANTY STATEMENT. FOR CANADIAN CUSTOMERS, EXCEPT FOR THE EXPRESS WARRANTIES CONTAINED IN THIS WARRANTY STATEMENT, DELL DISCLAIMS ALL OTHER WARRANTIES AND CONDITIONS, EXPRESS OR IMPLIED, STATUTORY OR OTHERWISE, FOR THE PRODUCT. FOR U.S. CUSTOMERS, ALL EXPRESS AND IMPLIED WARRANTIES FOR THE PRODUCT, INCLUDING BUT NOT LIMITED TO ANY IMPLIED WARRANTIES AND CONDITIONS OF MERCHANTABILITY AND FITNESS FOR A PARTICULAR PURPOSE ARE LIMITED IN TIME TO THE TERM OF THIS LIMITED WARRANTY. NO WARRANTIES, WHETHER EXPRESS OR IMPLIED, WILL APPLY AFTER THE LIMITED WARRANTY PERIOD HAS EXPIRED. SOME STATES OR JURISDICTIONS DO NOT ALLOW THE EXCLUSION OF CERTAIN IMPLIED WARRANTIES OR CONDITIONS, OR LIMITATIONS ON HOW LONG AN IMPLIED WARRANTY OR CONDITION LASTS, SO THIS LIMITATION MAY NOT APPLY TO YOU. THIS WARRANTY COVERAGE TERMINATES IF YOU SELL OR OTHERWISE TRANSFER THIS PRODUCT TO ANOTHER PARTY.

DELL DOES NOT ACCEPT LIABILITY BEYOND THE REMEDIES PROVIDED FOR IN THIS LIMITED WARRANTY OR FOR SPECIAL, INDIRECT, CONSEQUENTIAL OR INCIDENTAL DAMAGES, INCLUDING, WITHOUT LIMITATION, ANY LIABILITY FOR THIRD-PARTY CLAIMS AGAINST YOU FOR DAMAGES, FOR PRODUCTS NOT BEING AVAILABLE FOR USE, OR FOR LOST DATA OR LOST SOFTWARE. DELL'S LIABILITY WILL BE NO MORE THAN THE AMOUNT YOU PAID FOR THE PRODUCT THAT IS THE SUBJECT OF A CLAIM. THIS IS THE MAXIMUM AMOUNT FOR WHICH DELL IS RESPONSIBLE.

SOME STATES OR JURISDICTIONS DO NOT ALLOW THE EXCLUSION OR LIMITATION OF SPECIAL, INDIRECT, INCIDENTAL OR CONSEQUENTIAL DAMAGES, SO THE ABOVE LIMITATION OR EXCLUSION MAY NOT APPLY TO YOU.

### **Ink and Toner Cartridges Limited Warranty (Latin America Only)**

Dell Inc. warrants to the original purchaser of genuine Dell-branded Toner Cartridges that the cartridges will be free from defects resulting from material or manufacturing process for the life of the cartridge. For the original purchaser of genuine Dell-branded ink cartridges, Dell warrants that the cartridges will be free from defects resulting from material or manufacturing process for one year beginning from the date of delivery.

If this product presents defects resulting from either material or manufacturing process, it will be replaced without charge during the limited warranty period if returned to Dell.

In order to obtain the necessary information to enable the replacement, call the appropriate toll-free number. In Mexico, call 001-877-384-8979; in Puerto Rico, call 1-800-805-7545. In cases in which either the production of the cartridge has been discontinued or the cartridge is not available, Dell reserves the right, at its sole discretion, to choose between replacing it by a similar product or reimbursing you for the purchase cost.

This limited warranty does not apply to ink or Toner Cartridges that have been refilled or to defects resulting from misuse, abuse, accident, negligence, mishandling, improper storage or exposure to inappropriate environments.

Dell's liability for the malfunction or defect of hardware after the period of the legal warranty (and specifically the period of the legal warranty of defective products stated in the consumer protections rules), is limited to either the substitution of the product or the reimbursement as stated above. This warranty coverage terminates if you sell or otherwise transfer this product to a third party.

Dell does not accept any additional liability for patrimonial, emotional or any other kind of damage caused to the consumer and/or to a third party, which exceeds the established liability either in this limited warranty or in legal rules that may apply.

## **Dell™ Software License Agreement**

This is a legal agreement between you, the user, and Dell Products, L.P. (“Dell”). This agreement covers all software that is distributed with the Dell product, for which there is no separate license agreement between you and the manufacturer or owner of the software (collectively the “Software”). This agreement is not for the sale of Software or any other intellectual property. All title and intellectual property rights in and to Software is owned by the manufacturer or owner of the Software. All rights not expressly granted under this agreement are reserved by the manufacturer or owner of the Software. By opening or breaking the seal on the Software packet(s), installing or downloading the Software, or using the Software that has been preloaded or is embedded in your product, you agree to be bound by the terms of this agreement. If you do not agree to these terms, promptly return all Software items (disks, written materials, and packaging) and delete any preloaded or embedded Software.

The Software is protected by United States copyright laws and international treaties. You may make one copy of the Software solely for backup or archival purposes or transfer it to a single hard disk provided you keep the original solely for backup or archival purposes. You may not rent or lease the Software or copy the written materials accompanying the Software, but you may transfer the Software and all accompanying materials on a permanent basis if you retain no copies and the recipient agrees to the terms hereof. Any transfer must include the most recent update and all prior versions. You may not reverse engineer, decompile or disassemble the Software. If the package accompanying your computer contains compact discs, 3.5" and/or 5.25" disks, you may use only the disks appropriate for your computer. You may not use the disks on another computer or network, or loan, rent, lease, or transfer them to another user except as permitted by this agreement.

### **Limited Warranty**

Dell warrants that the Software disks will be free from defects in materials and workmanship under normal use for ninety (90) days from the date you receive them. This warranty is limited to you and is not transferable. Any implied warranties are limited to ninety (90) days from the date you receive the Software. Some jurisdictions do not allow limits on the duration of an implied warranty, so this limitation may not apply to you. The entire liability of Dell and its suppliers, and your exclusive remedy, shall be (a) return of the price paid for the Software or (b) replacement of any disk not meeting this warranty that is sent with a return authorization number to Dell, at your cost and risk. This limited warranty is void if any disk damage has resulted from accident, abuse, misapplication, or service or modification by someone other than Dell. Any replacement disk is warranted for the remaining original warranty period or thirty (30) days, whichever is longer.

Dell does NOT warrant that the functions of the Software will meet your requirements or that operation of the Software will be uninterrupted or error free. You assume responsibility for selecting the Software to achieve your intended results and for the use and results obtained from the Software.

DELL, ON BEHALF OF ITSELF AND ITS SUPPLIERS, DISCLAIMS ALL OTHER WARRANTIES, EXPRESS OR IMPLIED, INCLUDING, BUT NOT LIMITED TO, IMPLIED WARRANTIES OF MERCHANTABILITY AND FITNESS FOR A PARTICULAR PURPOSE,

FOR THE SOFTWARE AND ALL ACCOMPANYING WRITTEN MATERIALS. This limited warranty gives you specific legal rights; you may have others, which vary from jurisdiction to jurisdiction.

IN NO EVENT SHALL DELL OR ITS SUPPLIERS BE LIABLE FOR ANY DAMAGES WHATSOEVER (INCLUDING, WITHOUT LIMITATION, DAMAGES FOR LOSS OF BUSINESS PROFITS, BUSINESS INTERRUPTION, LOSS OF BUSINESS INFORMATION, OR OTHER PECUNIARY LOSS) ARISING OUT OF USE OR INABILITY TO USE THE SOFTWARE, EVEN IF ADVISED OF THE POSSIBILITY OF SUCH DAMAGES. Because some jurisdictions do not allow an exclusion or limitation of liability for consequential or incidental damages, the above limitation may not apply to you.

### **U.S. Government Restricted Rights**

The software and documentation are "commercial items" as that term is defined at 48 C.F.R. 2.101, consisting of "commercial computer software" and "commercial computer software documentation" as such terms are used in 48 C.F.R. 12.212. Consistent with 48 C.F.R. 12.212 and 48 C.F.R. 227.7202-1 through 227.7202-4, all U.S. Government end users acquire the software and documentation with only those rights set forth herein. Contractor/manufacturer is Dell Products, L.P., One Dell Way, Round Rock, Texas 78682.

### **General**

This license is effective until terminated. It will terminate upon the conditions set forth above or if you fail to comply with any of its terms. Upon termination, you agree that the Software and accompanying materials, and all copies thereof, will be destroyed. This agreement is governed by the laws of the State of Texas. Each provision of this agreement is severable. If a provision is found to be unenforceable, this finding does not affect the enforceability of the remaining provisions, terms, or conditions of this agreement. This agreement is binding on successors and assigns. Dell agrees and you agree to waive, to the maximum extent permitted by law, any right to a jury trial with respect to the Software or this agreement. Because this waiver may not be effective in some jurisdictions, this waiver may not apply to you. You acknowledge that you have read this agreement, that you understand it, that you agree to be bound by its terms, and that this is the complete and exclusive statement of the agreement between you and Dell regarding the Software.

## **Regulatory**

Electromagnetic Interference (EMI) is any signal or emission, radiated in free space or conducted along power or signal leads, that endangers the functioning of a radio navigation or other safety service or seriously degrades, obstructs, or repeatedly interrupts a licensed radio communications service. Radio communications services include but are not limited to AM/FM commercial

broadcast, television, cellular services, radar, air-traffic control, pager, and Personal Communication Services (PCS). These licensed services, along with unintentional radiators such as digital devices, including computer systems, contribute to the electromagnetic environment.

Electromagnetic Compatibility (EMC) is the ability of items of electronic equipment to function properly together in the electronic environment. While this computer system has been designed and determined to be compliant with regulatory agency limits for EMI, there is no guarantee that interference will not occur in a particular installation. If this equipment does cause interference with radio communications services, which can be determined by turning the equipment off and on, you are encouraged to try to correct the interference by one or more of the following measures:

- Reorient the receiving antenna.
- Relocate the computer with respect to the receiver.
- Move the computer away from the receiver.
- Plug the computer into a different outlet so that the computer and the receiver are on different branch circuits.

If necessary, consult a Dell Technical Support representative or an experienced radio/television technician for additional suggestions.

For more information, see *User's Guide*.





# Index

## Numerics

1-Year End-User Manufacturer  
Guarantee , 89

## C

Canceling a job , 36  
Changing printer settings from  
the operator panel , 34  
Connecting the printer  
Locally , 20

## D

Dell supplies management sys-  
tem , 38  
Disable menus from the operator  
panel , 35  
Drivers, Installing , 20

## F

Factory defaults, Restoring , 35

## I

Imaging drum  
Installing , 41  
Replacing , 40  
Installing

Imaging drum , 41  
PPD file , 31  
Printer drivers  
For local printing , 20  
on Macintosh , 27  
Toner cartridge , 44

## L

Loading paper  
Multipurpose feeder , 15  
Standard tray , 12  
Loading transparencies  
Multipurpose feeder , 15  
Standard tray , 12  
Local printing , 20

## M

Menus, Disabled , 35  
Multipurpose feeder  
Loading paper , 15  
Loading transparencies , 15

## N

Network printing , 23

## O

Operator panel  
Changing printer settings , 34  
Disable menus , 35  
Initializing NV memory , 35  
Ordering supplies , 2

## P

PPD file , 31  
Printing  
Local , 19  
Menu settings page , 24  
Network , 23  
Network setup page , 24  
with Macintosh , 27  
Printing a job , 36

## R

Replacing  
Imaging drum , 40  
Toner cartridge , 43  
Restoring factory defaults , 35

## S

Safety instruction , 9

- Software applications
  - Software update , 38
  - Status monitor , 37
  - Toner re-order , 38
- Software update , 38
- Status monitor , 37
- Supplies, Ordering , 2

## **T**

- Toner cartridge
  - Installing , 44
  - Replacing , 43
- Toner re-order window, Using , 38
- Toner, Ordering , 2

## **W**

- warranty , 81